

OSNOVNA ŠOLA VUZENICA

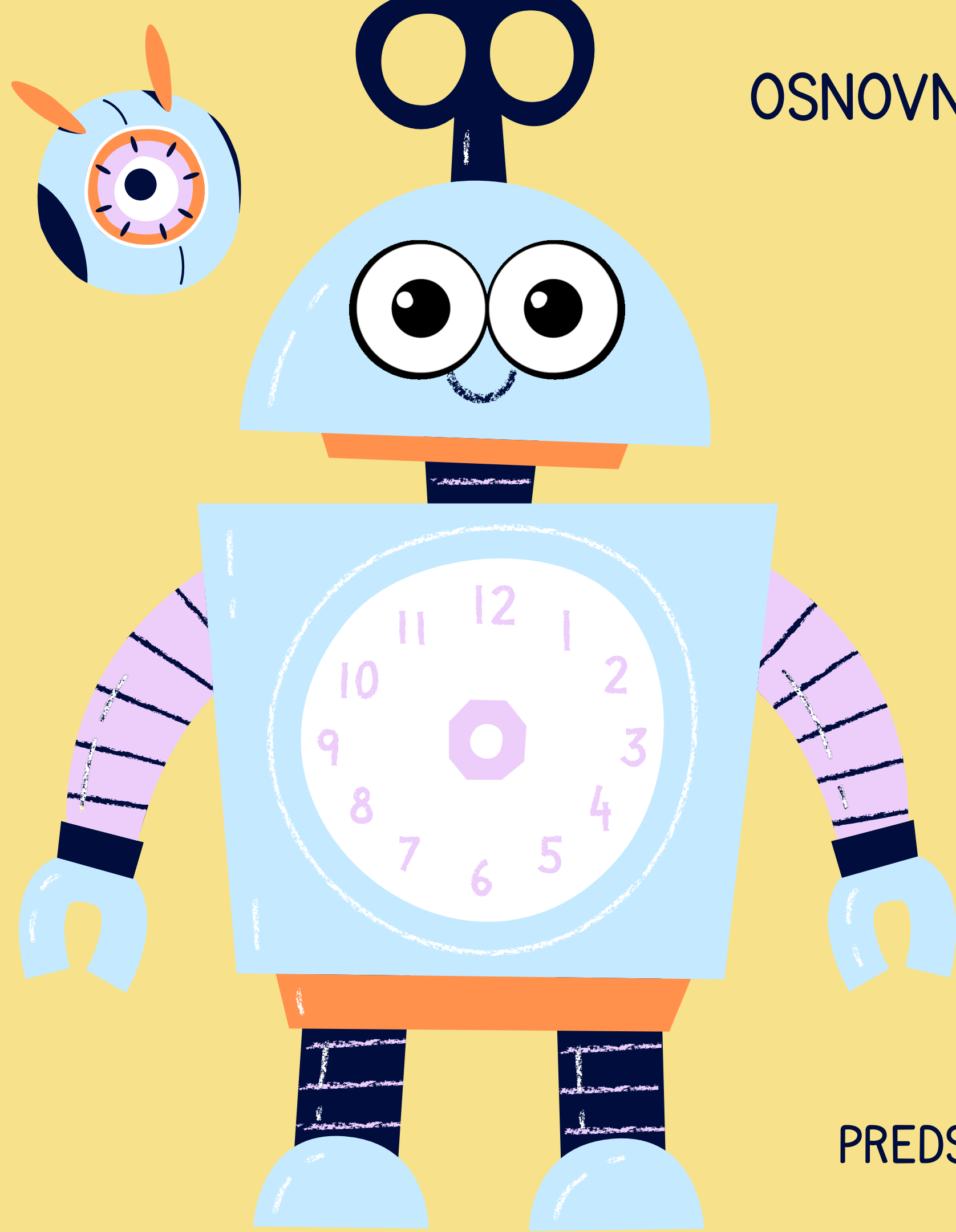

RIN

v 2. razredu

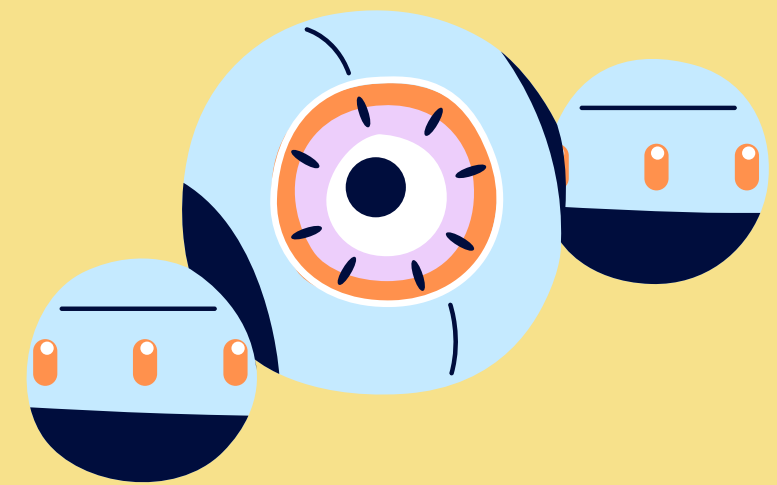

PREDSTAVITEV PRIPRAVILA: Andreja Švajger

Kaj smo spoznali?

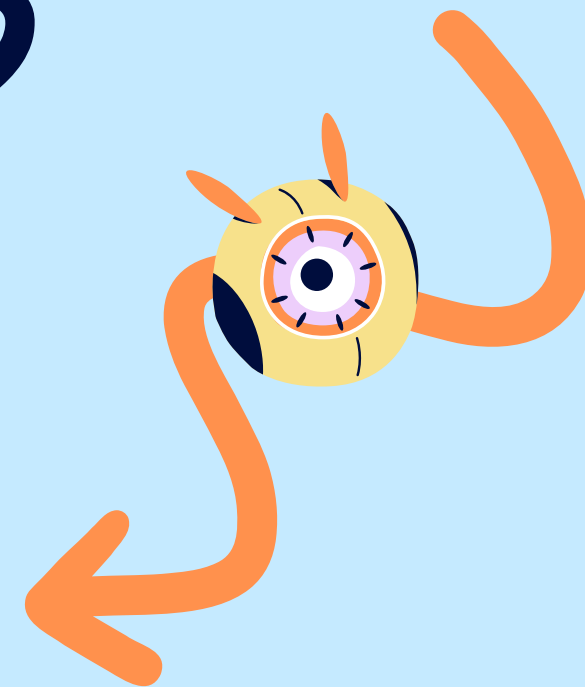
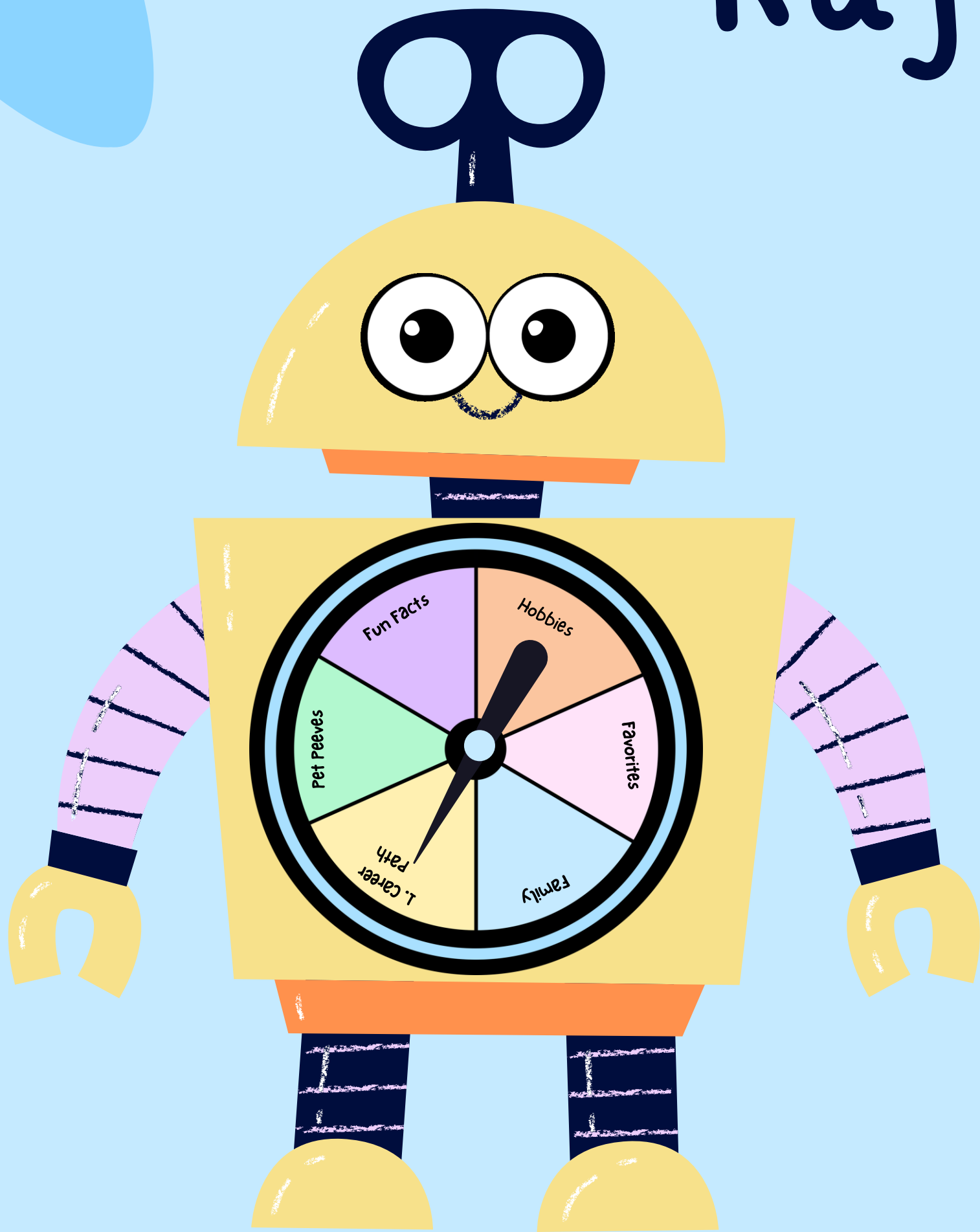

1 RAČUNALNIŠKO RAZMIŠLJANJE SKOZI MREŽE

2 ROBOTA BEE BOT

3 ROBOTA mTINY

4 OBISK PODJETJA STROKA.SI



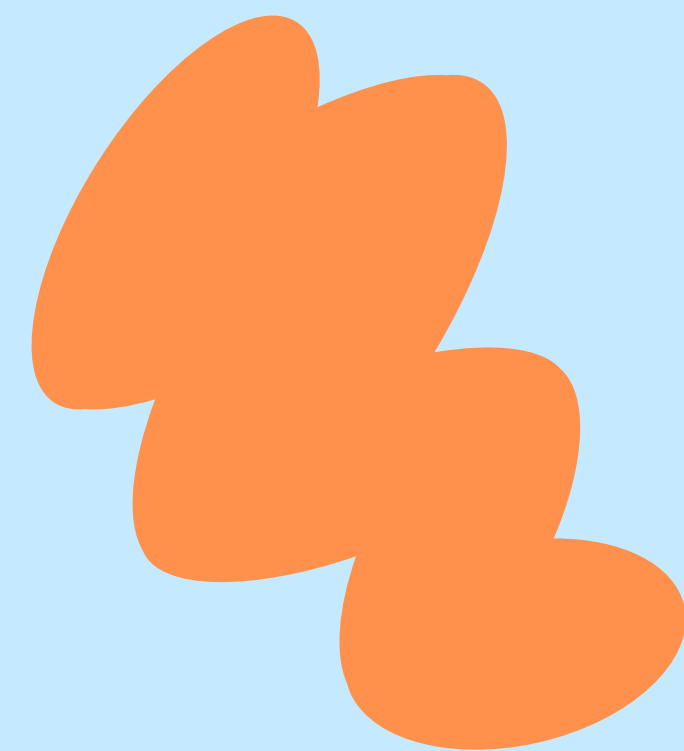

RAČUNALNIŠKO MIŠLJENJE SKOZI MREŽE



LEGO KODIRANJE

				1	1				
				2	2				
			2	2	2	3			
			4	2	2	2			
		2	2	2	5	2	4		
		5	2	2	2	2	2		
		2	2	5	5	2	2		
	2	2	2	3	2	2	2	5	
	5	3	2	2	2	4	2	2	
				6	6				



Grade:

Date:

Name:

ŽIVALSKÉ KODE

KLJUČI DO KOD

Ali lahko razvozlate spodnje besede?
Uporabite ključ, da ugotovite kodo.

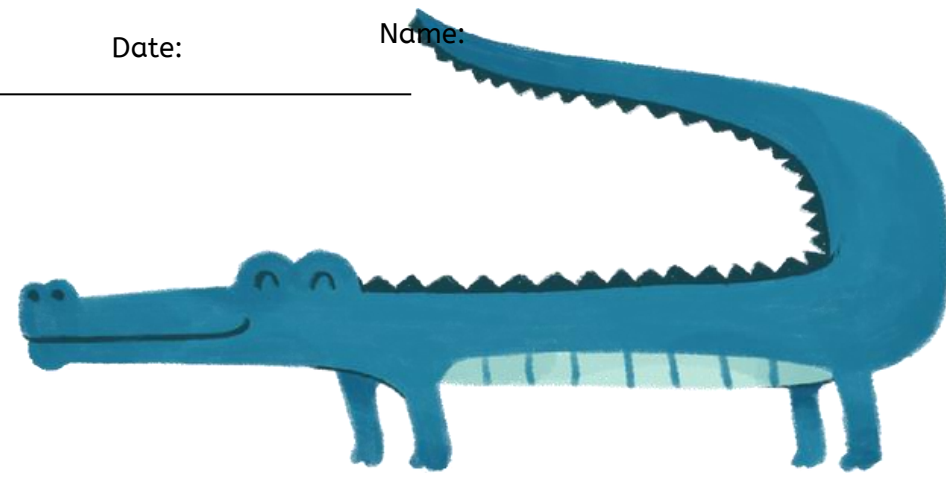

	A	B	C	Č	D	E	F	G	H	I	J	K
L	M	N	O	P	R	S	Š	T	U	V	Z	Ž

1

6

2

7

3

8

4

9

5

10

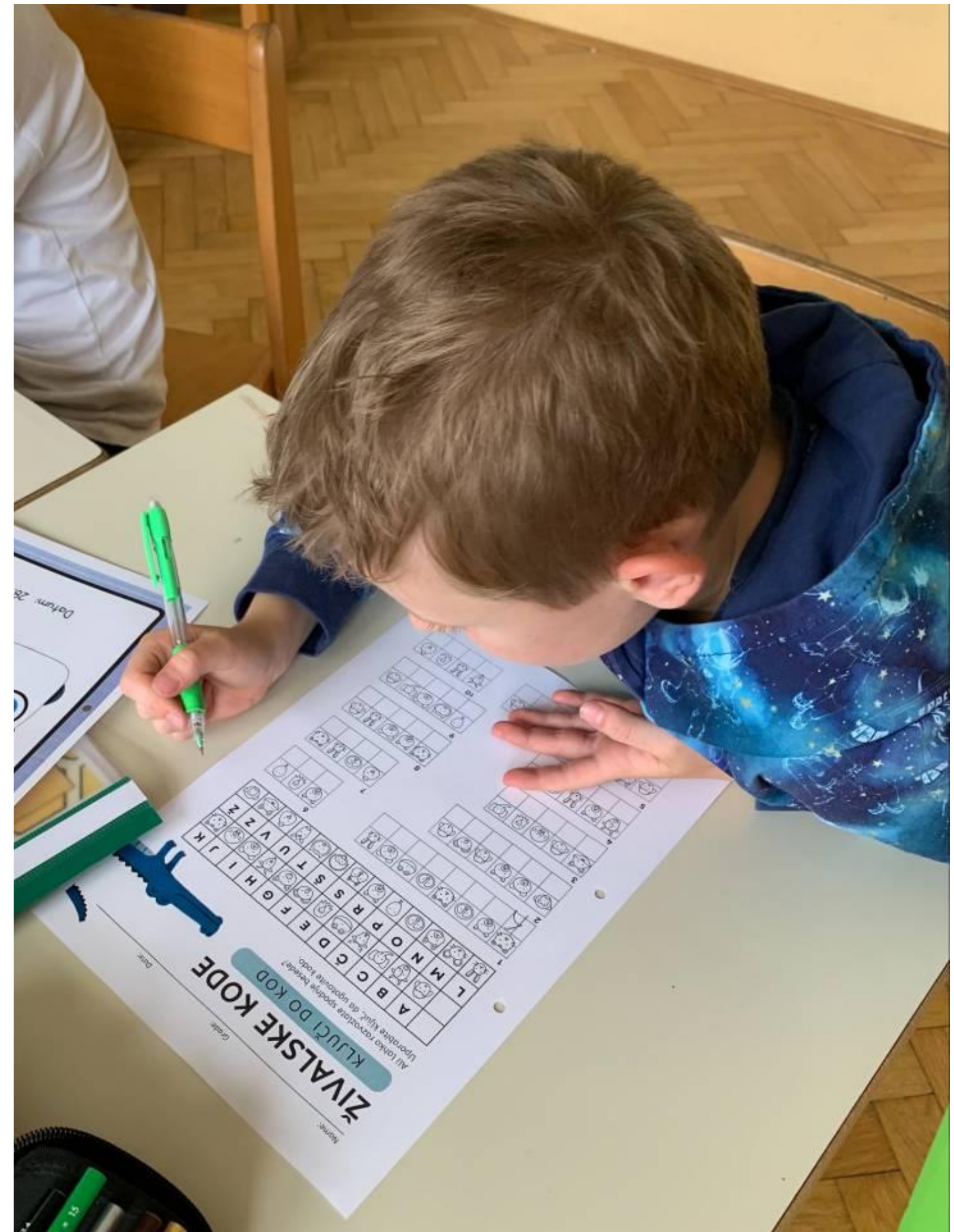

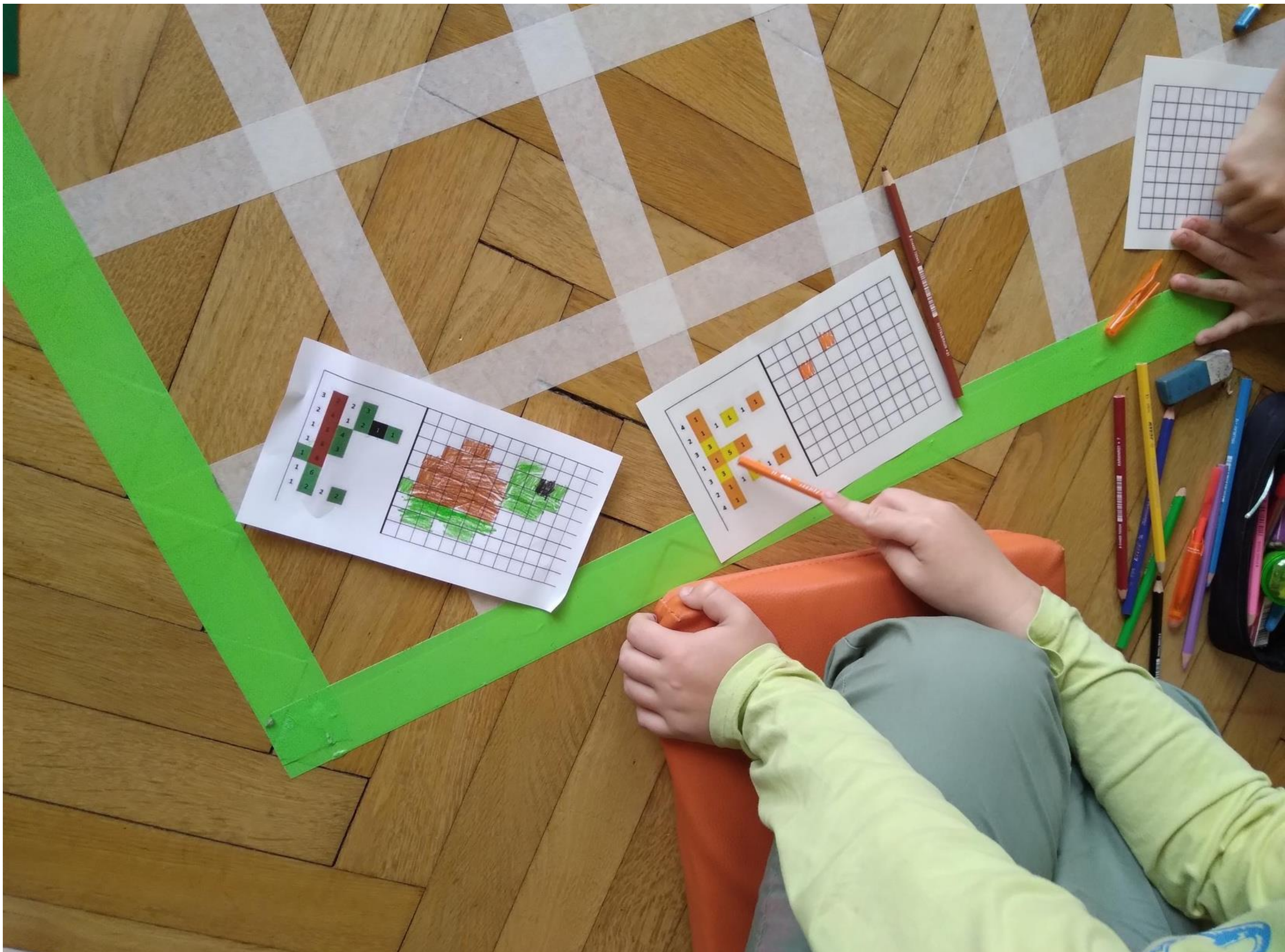



ROBOT BEE BOT

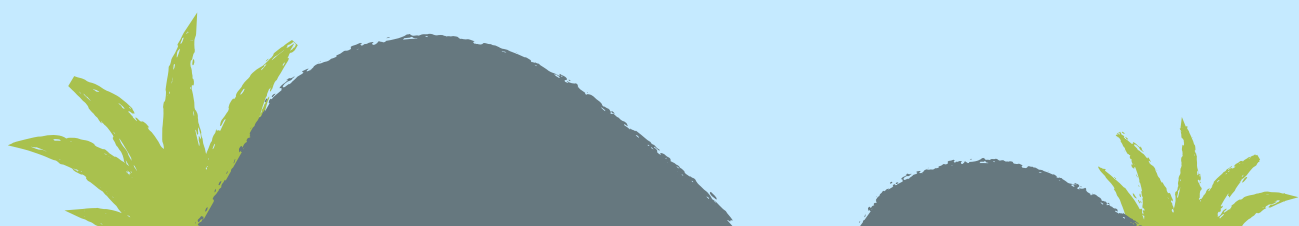

BEE BOT KODIRANJE

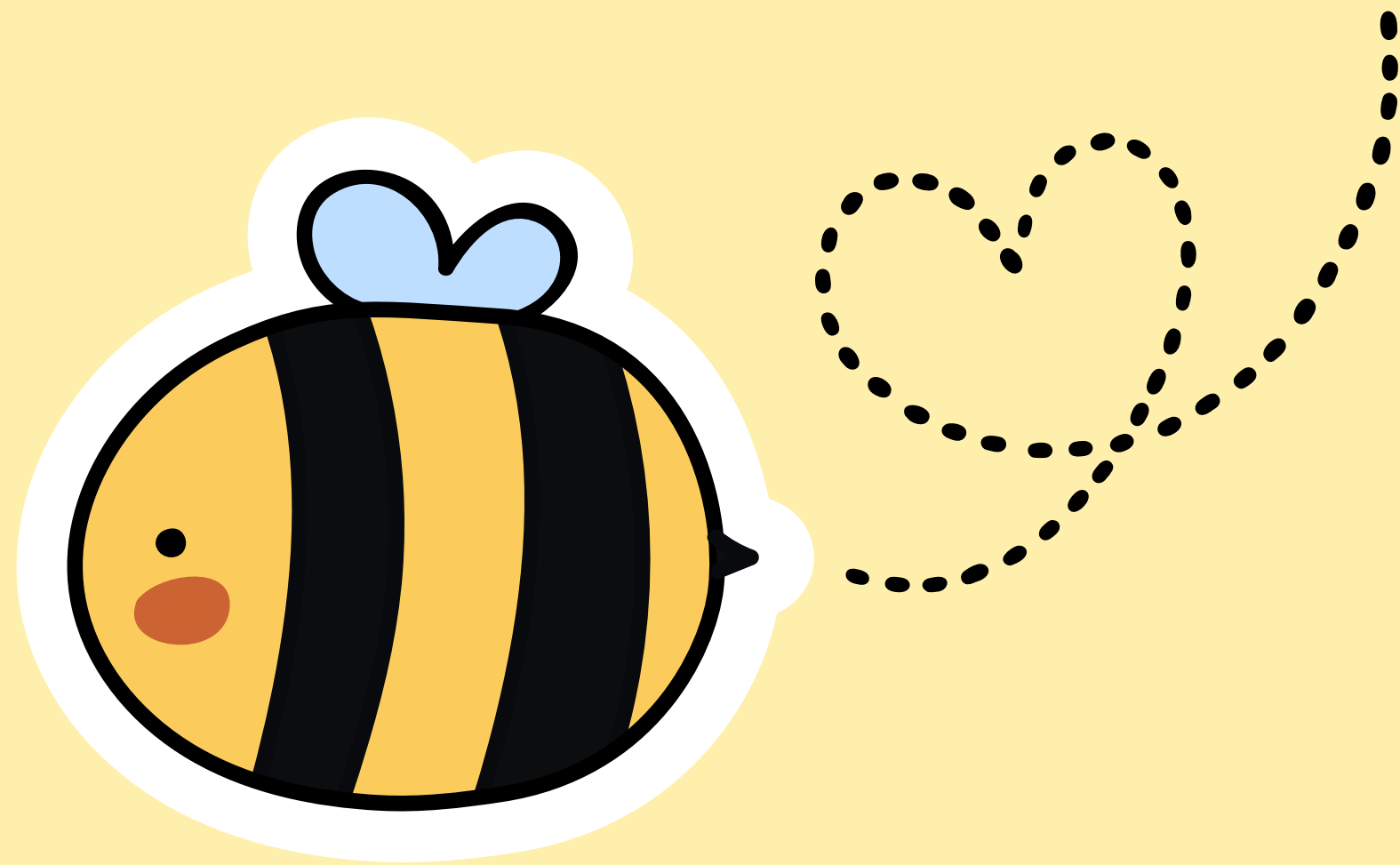

Bee-Bot je majhen robot, ki uporabniku pomaga pri učenju osnovnih konceptov kodiranja.

Kodiranje Bee-Bota vključuje uporabo smernih ukazov za programiranje robota, da se premika v različne smeri. Uporabnik vnese ukaze, kot so naprej, nazaj, levo in desno.

Bee Bot nato izvede te ukaze.

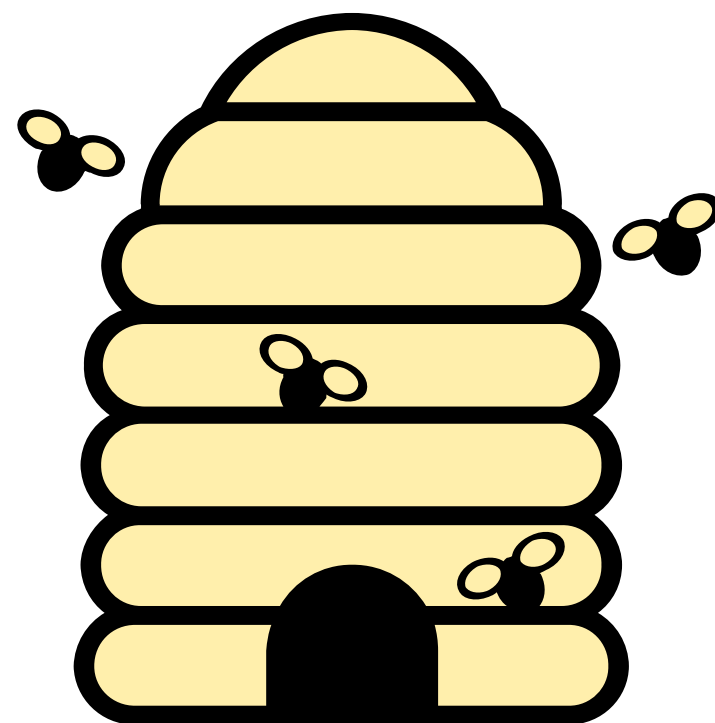

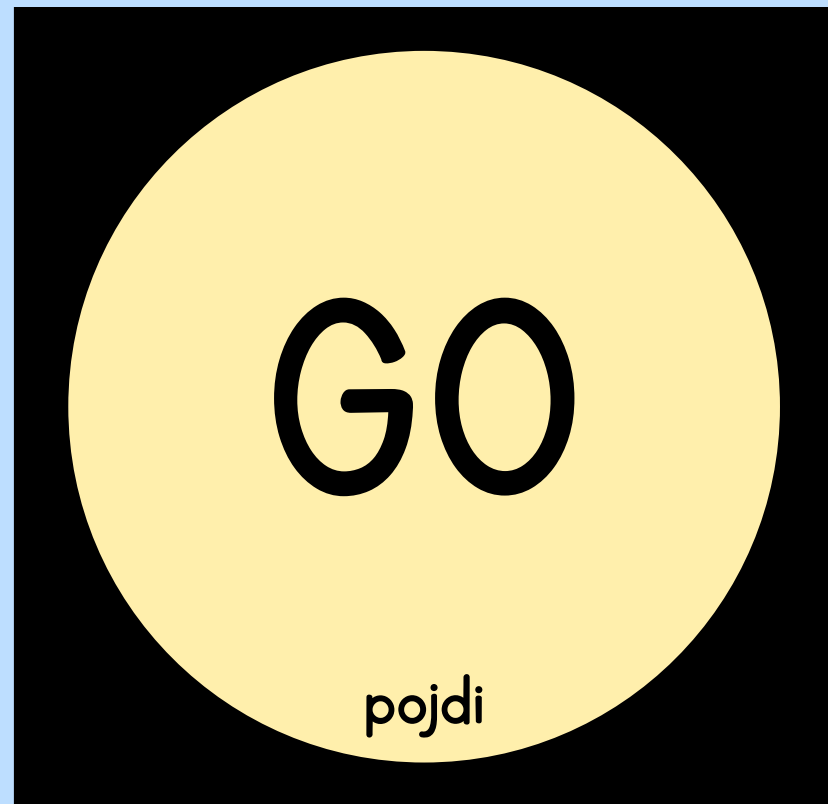
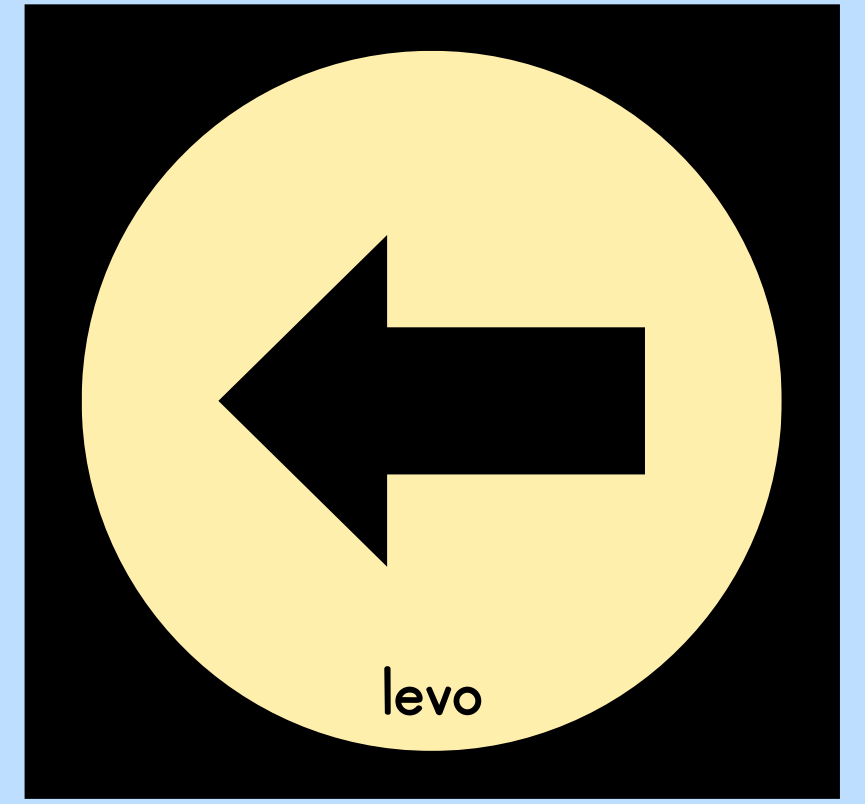
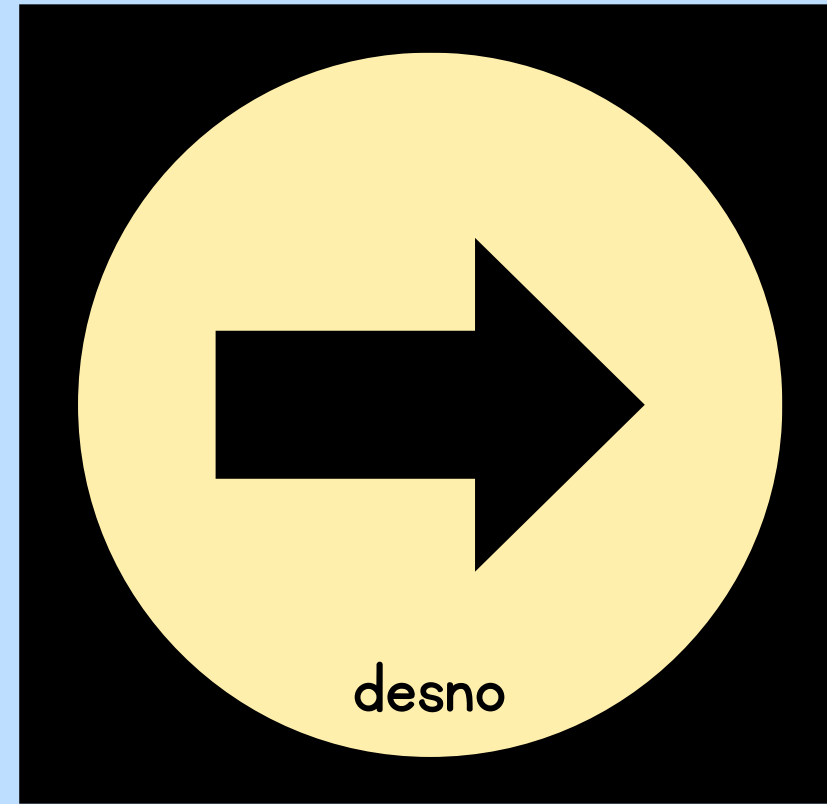
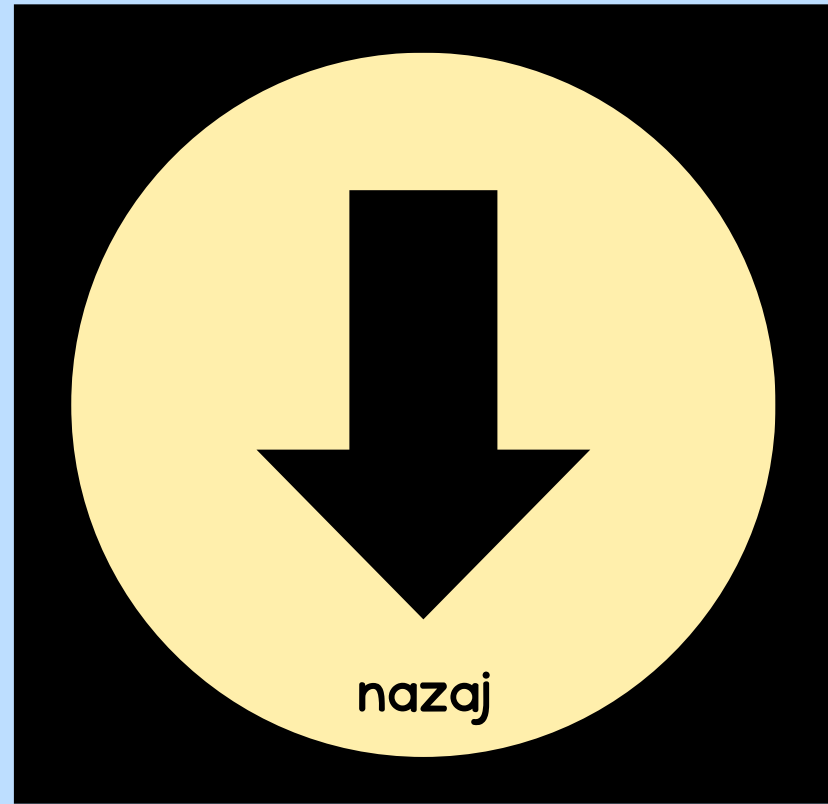
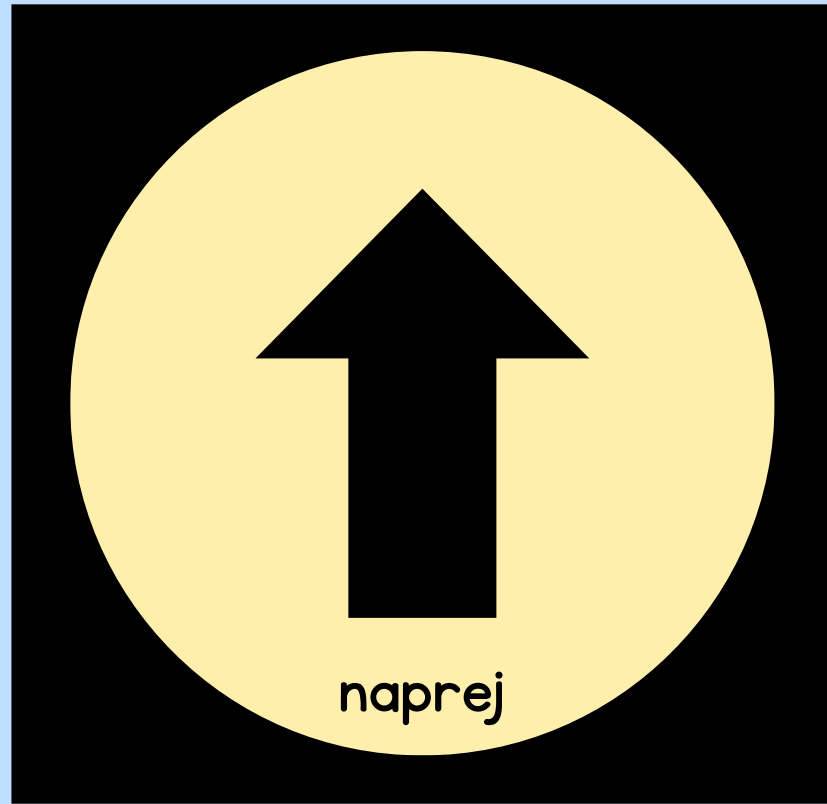

VADILI SMO PISANJE UKAZOV ZA BEE BOT
NA NASLEDNJIH MREŽAH IN NATO PREVERILI PRAVILNOST Z
ROBOTOM.

Pomagaj Bee Botu najti svoj panj. S pomočjo kartic s smermi nariši pot tako, da jih vstaviš v spodnja polja. Z robotom, preizkusi, če si bil natančen.

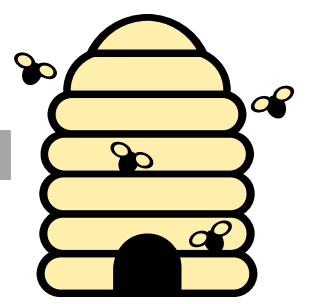
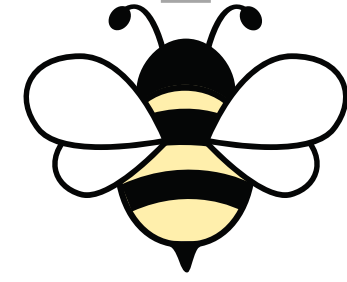



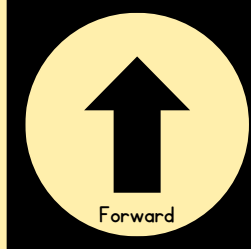
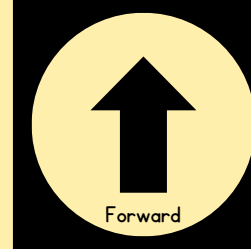
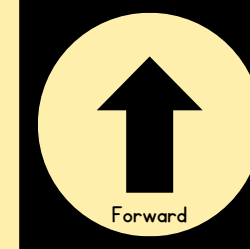
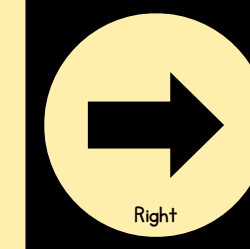
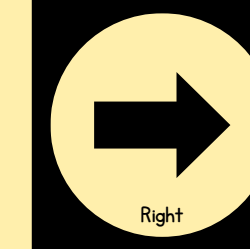
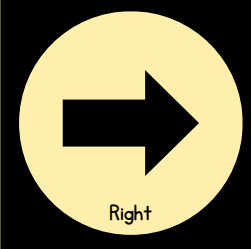
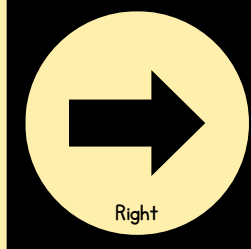
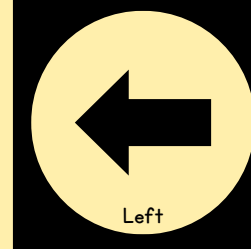
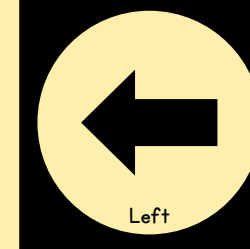
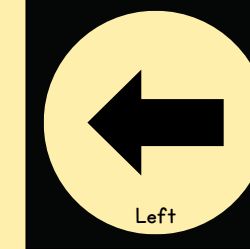
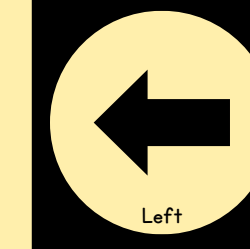
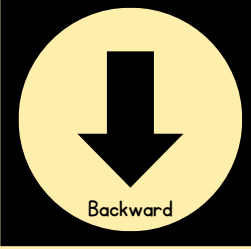
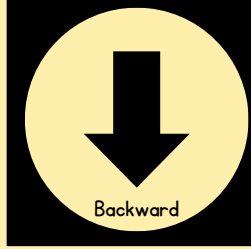
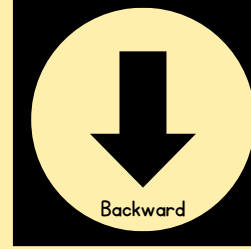
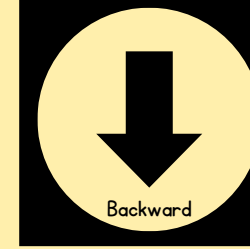
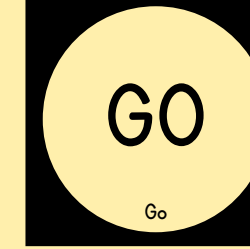
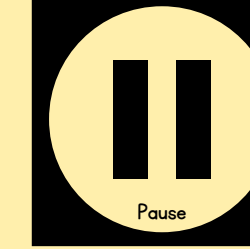

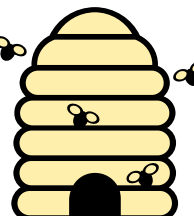
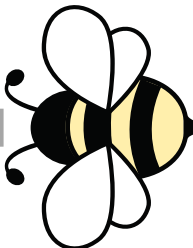
A 4x4 grid with a Bee Bot in the bottom-left cell and a Beehive in the top-right cell. A grey path starts from the Bee Bot, moves up to the second row, then right to the third column, and finally down to the Beehive.

 Forward	 Forward	 Forward	 Forward	 Right	 Right
 Right	 Right	 Left	 Left	 Left	 Left
 Backward	 Backward	 Backward	 Backward	 Go	 Pause

			
			

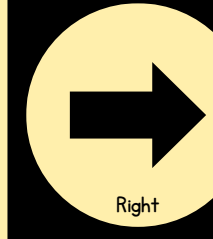
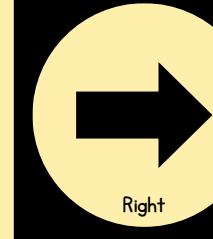
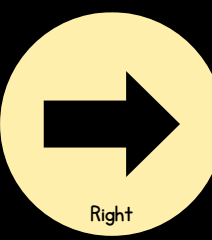
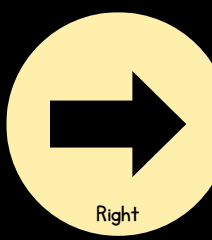
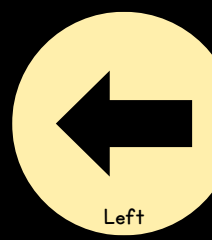
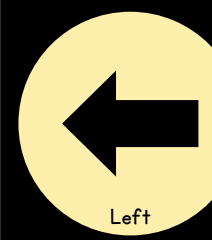
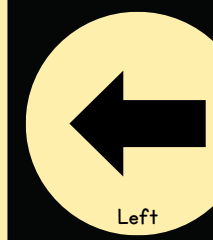
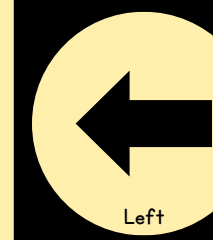
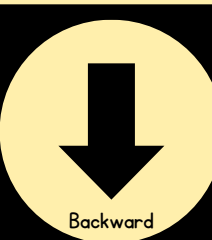
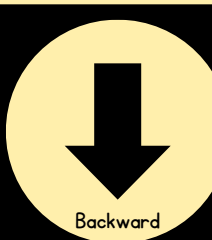
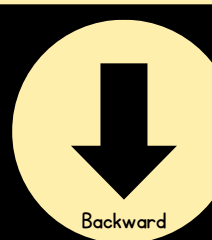
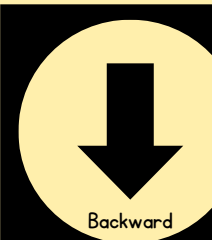
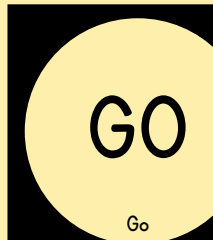
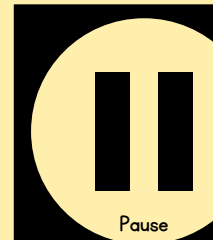

A 4x4 grid with a blue border. A grey path starts at a beehive in the top-left cell, moves down to the second row, right to the second column, down to the third row, and right to the third column, ending at a bee. The path consists of 10 segments.

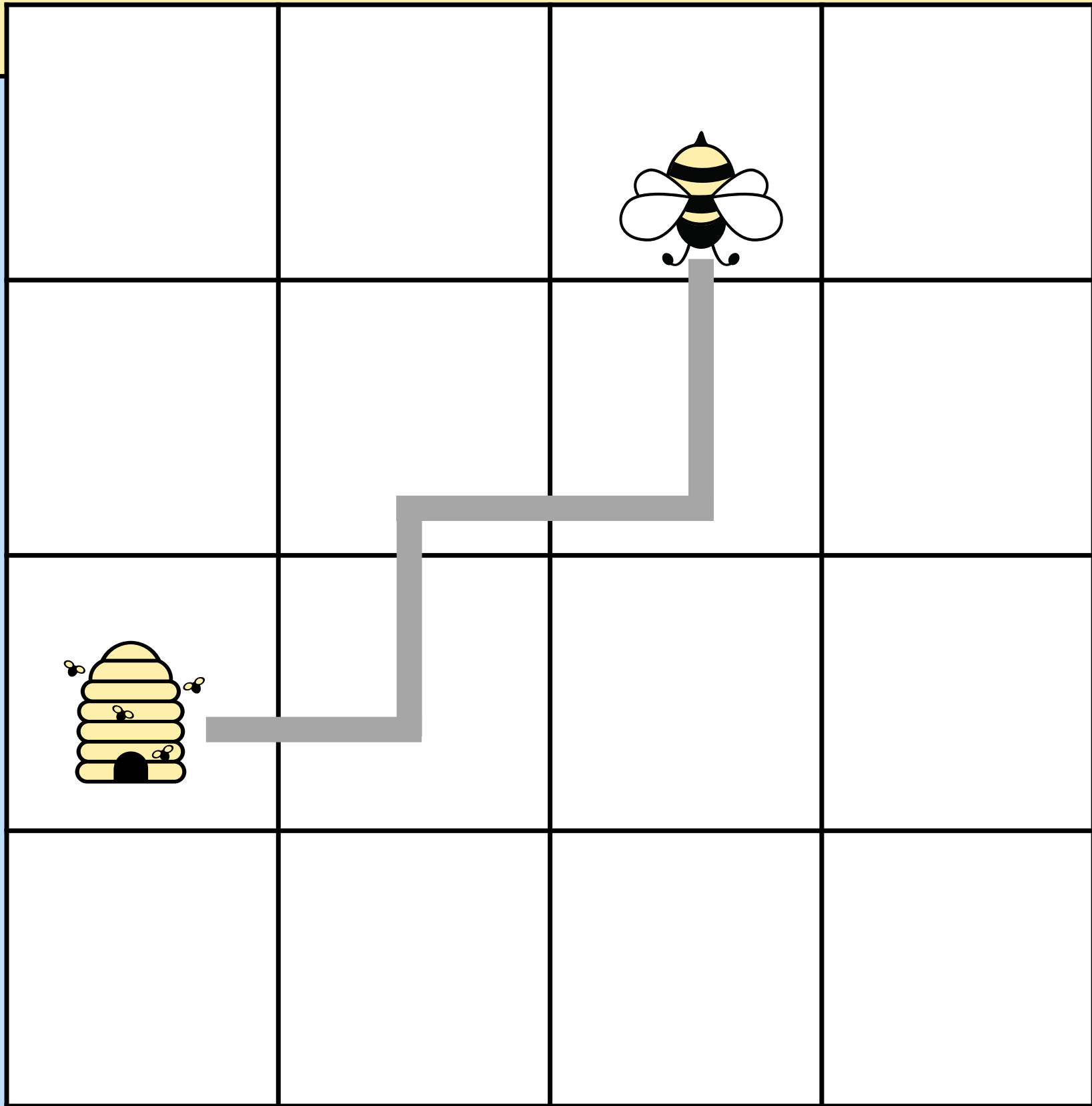
 Forward	 Forward	 Forward	 Forward	 Right	 Right
 Right	 Right	 Left	 Left	 Left	 Left
 Backward	 Backward	 Backward	 Backward	 Go	 Pause

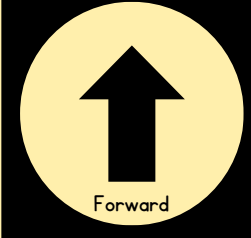
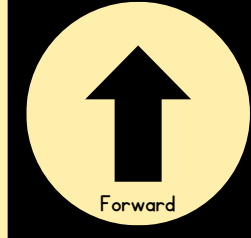
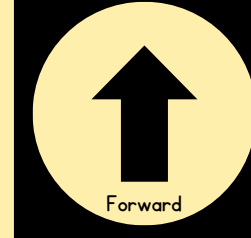
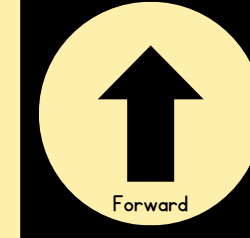
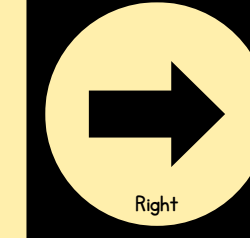
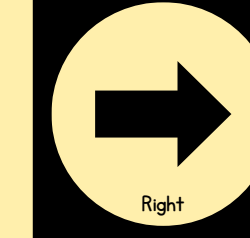
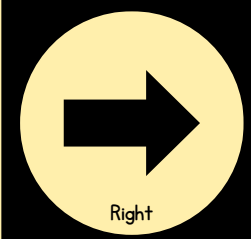
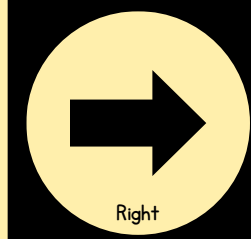
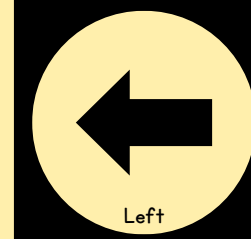
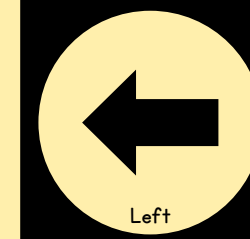
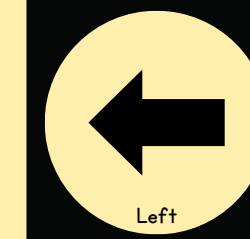
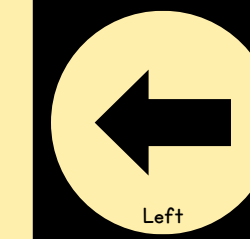
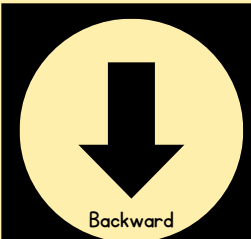
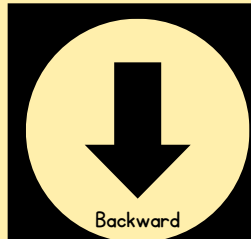
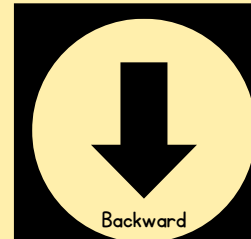
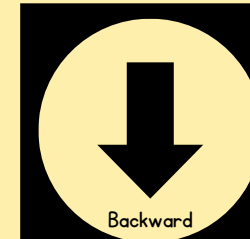
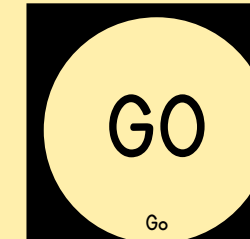
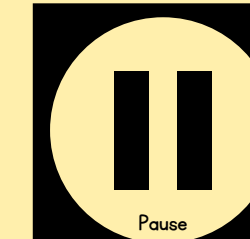

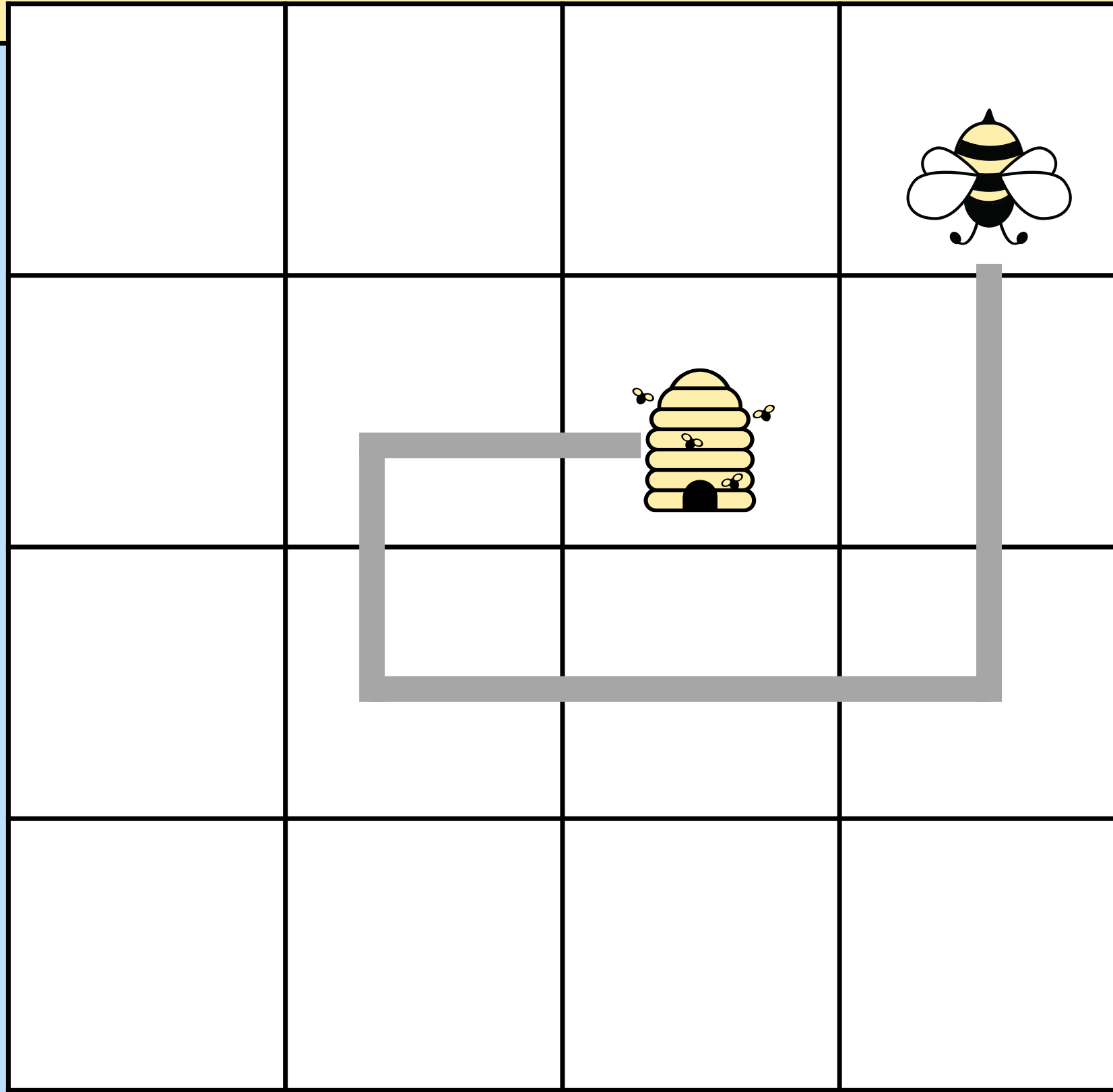
 Forward	 Forward	 Forward	 Forward	 Right	 Right
 Right	 Right	 Left	 Left	 Left	 Left
 Backward	 Backward	 Backward	 Backward	 Go	 Pause

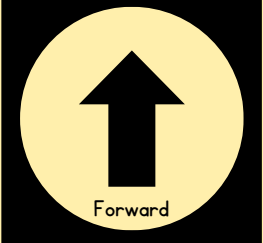

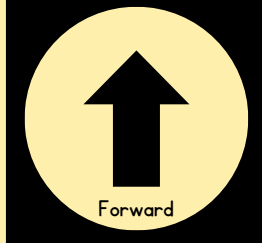
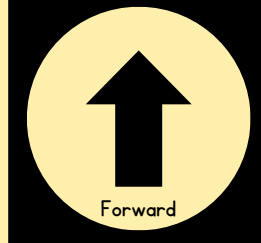
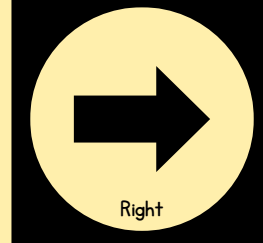
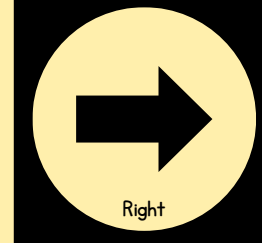
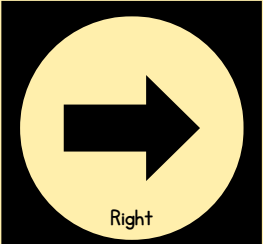
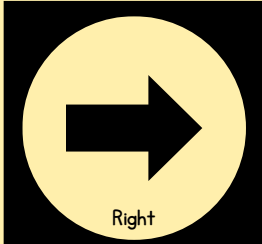
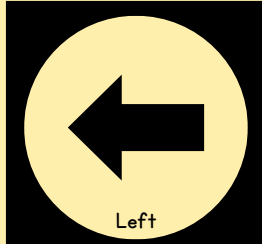
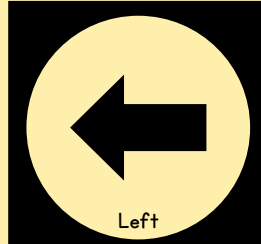
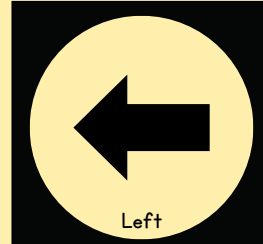
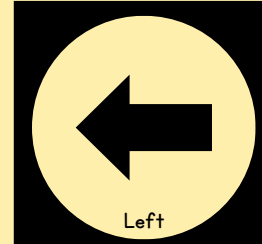
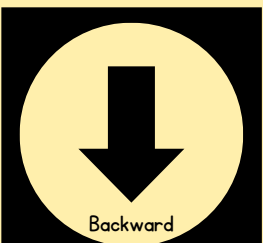
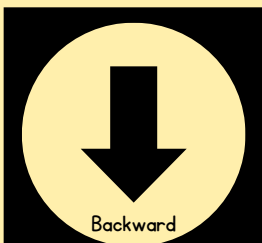
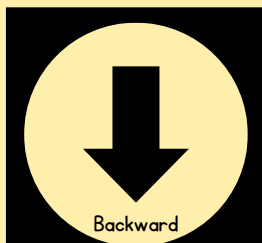
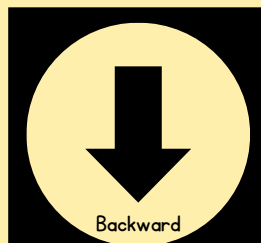
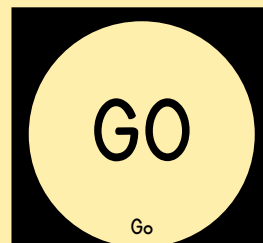
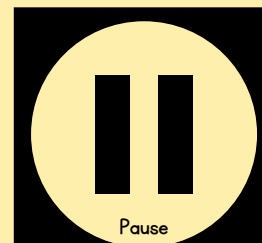
 Forward	 Forward	 Forward	 Forward	 Right	 Right
 Right	 Right	 Left	 Left	 Left	 Left
 Backward	 Backward	 Backward	 Backward	 Go	 Pause

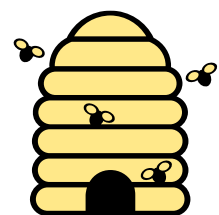

DELAVNICA 1: ROBOTEK BEE-BOT

DATUM: 14. MAJ 2025

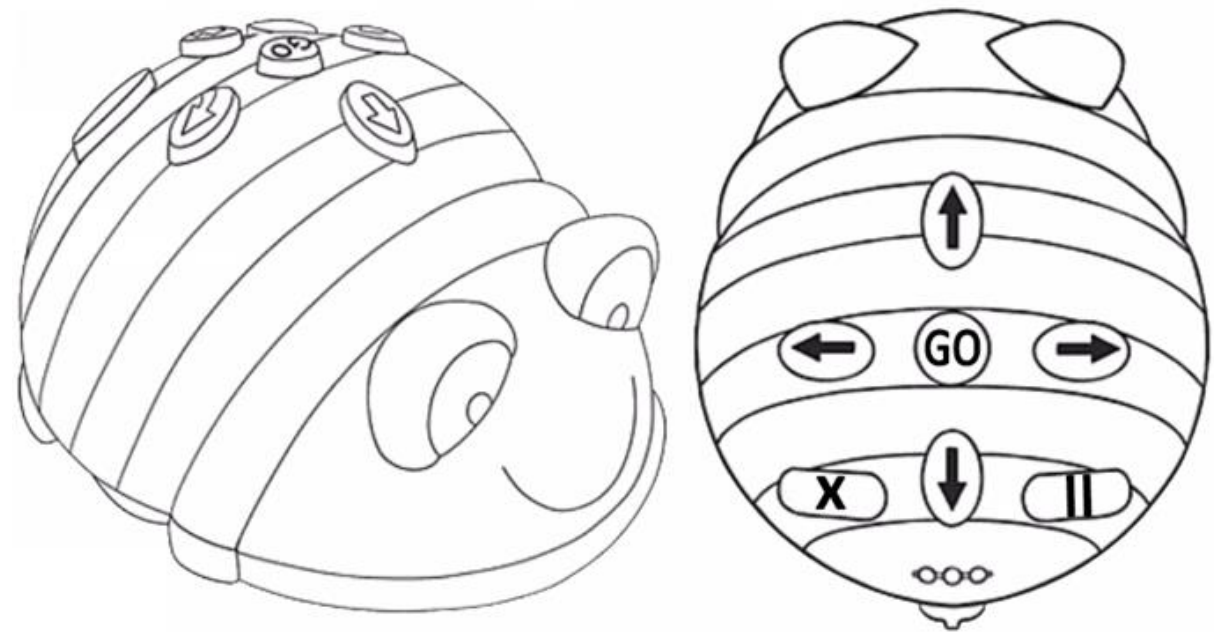

Pomagajte čebelici najti svoj panj. Narišite pot in nato v spodnje kvadratke narišite ukaze, da prikazete pot. Preizkusite s svojim Bee Botom.

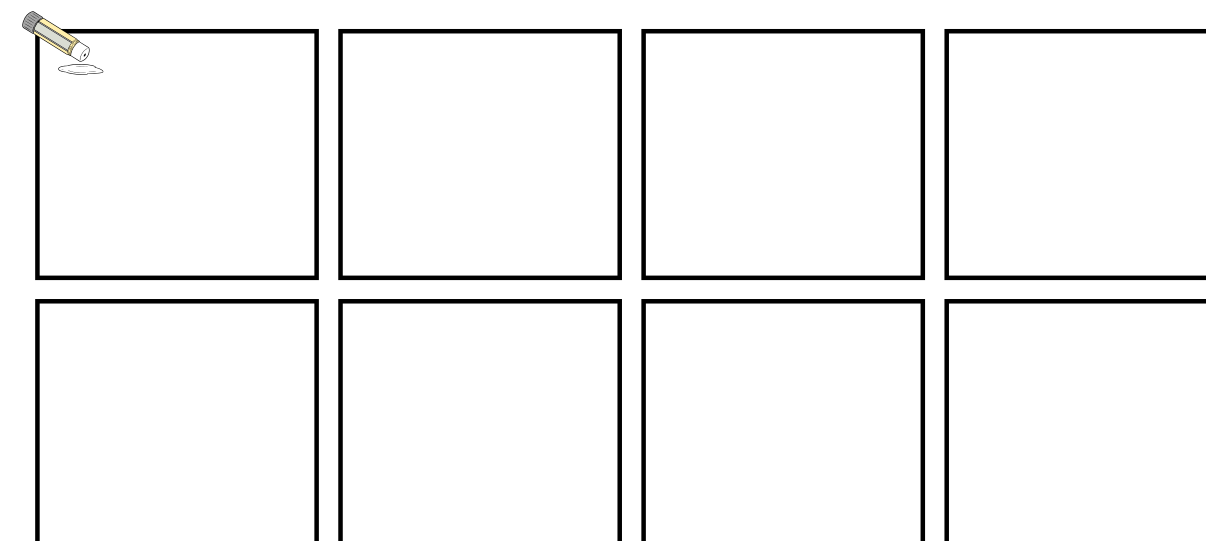
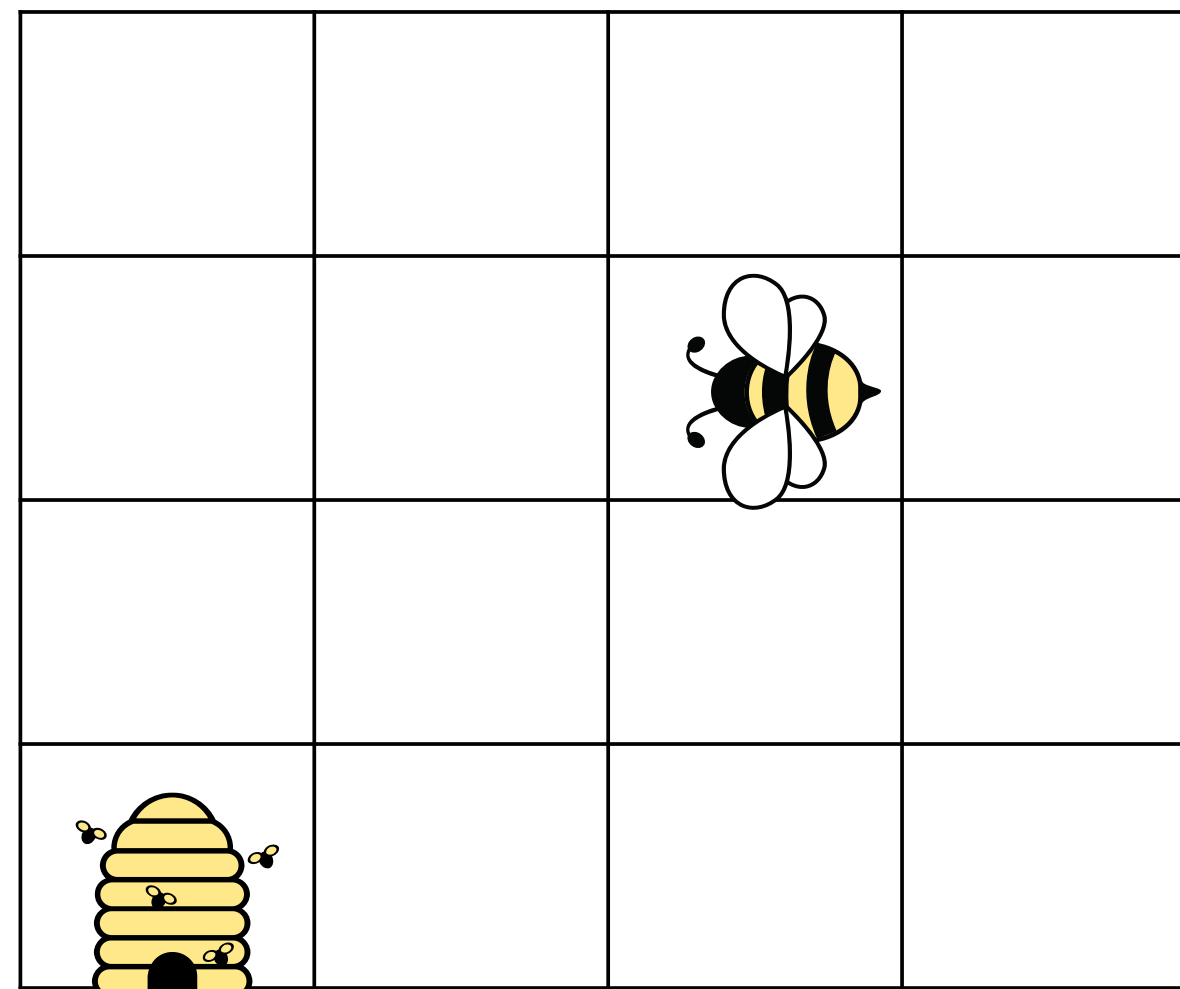

Pomagajte čebelici najti svoj panj. Narišite pot in nato v spodnje kvadratke narišite ukaze, da prikažete pot. Preizkusite s svojim Bee Botom.

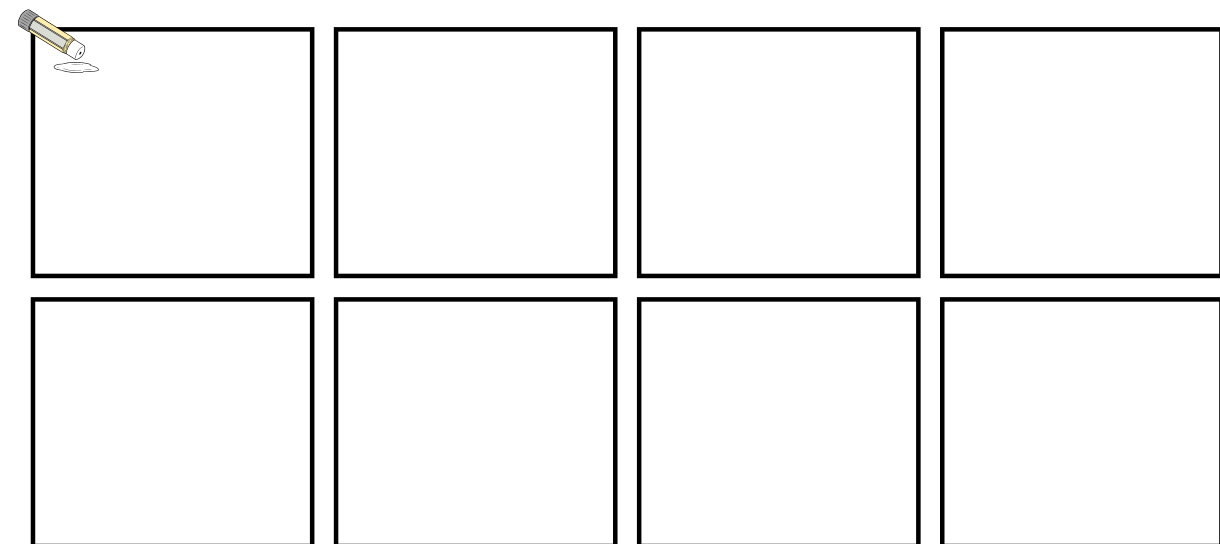
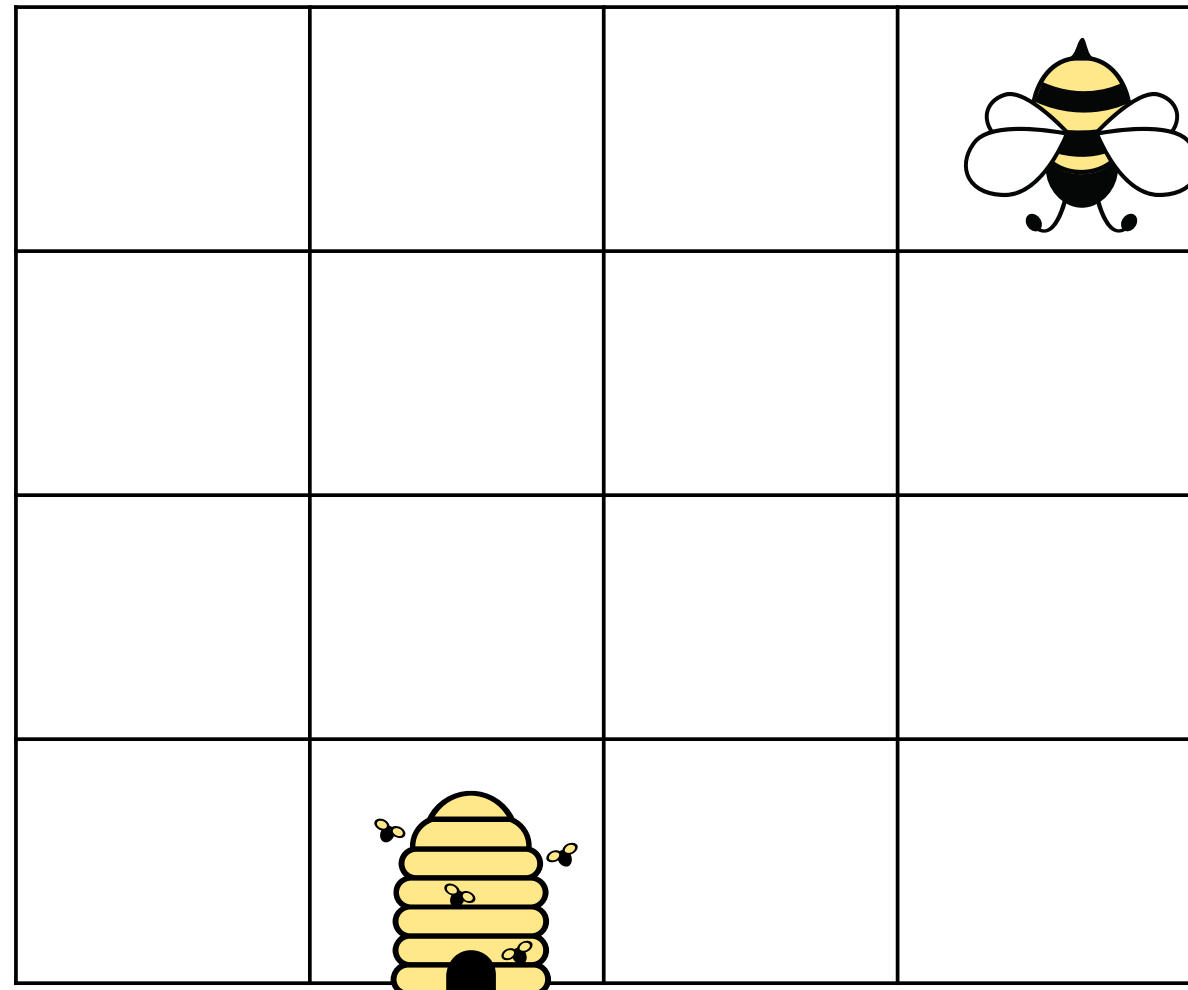

Pomagajte čebelici najti svoj panj. Narišite pot in nato v spodnje kvadratke narišite ukaze, da prikažete pot. Preizkusite s svojim Bee Botom.

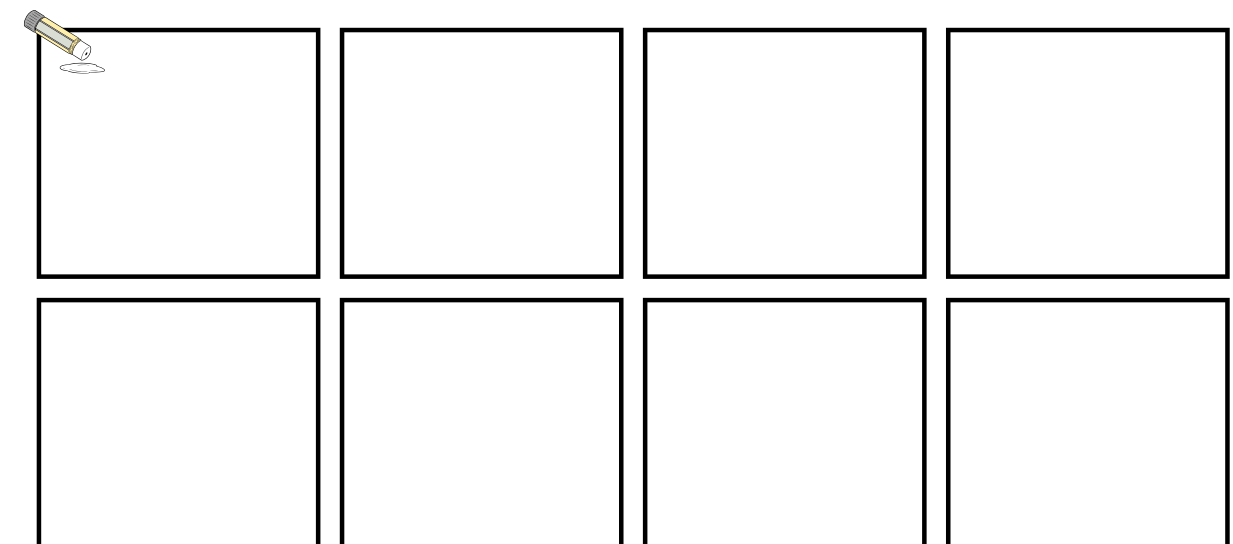
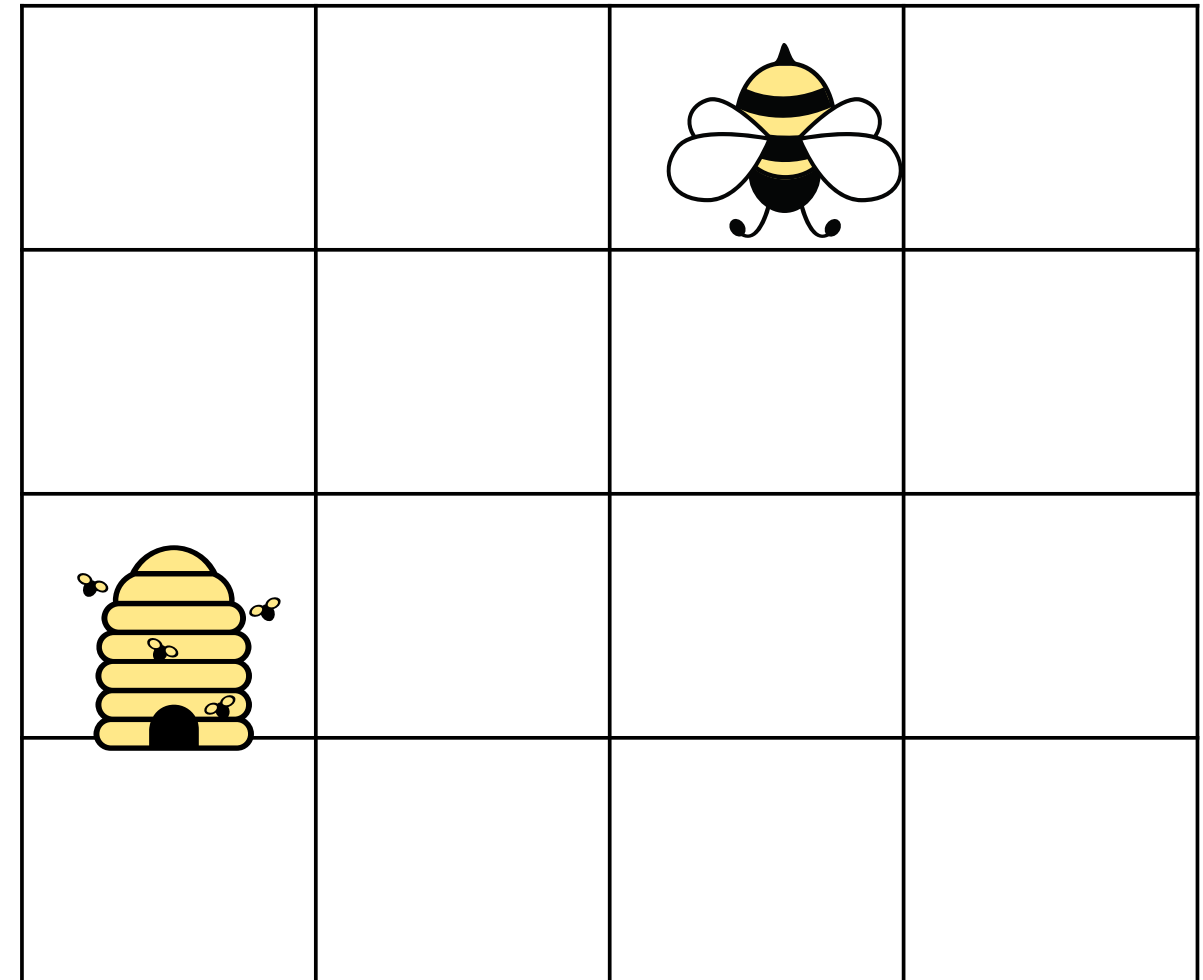

BEE BOT KODIRANJE

Napiši algoritem od ZAČETKA do KONCA.

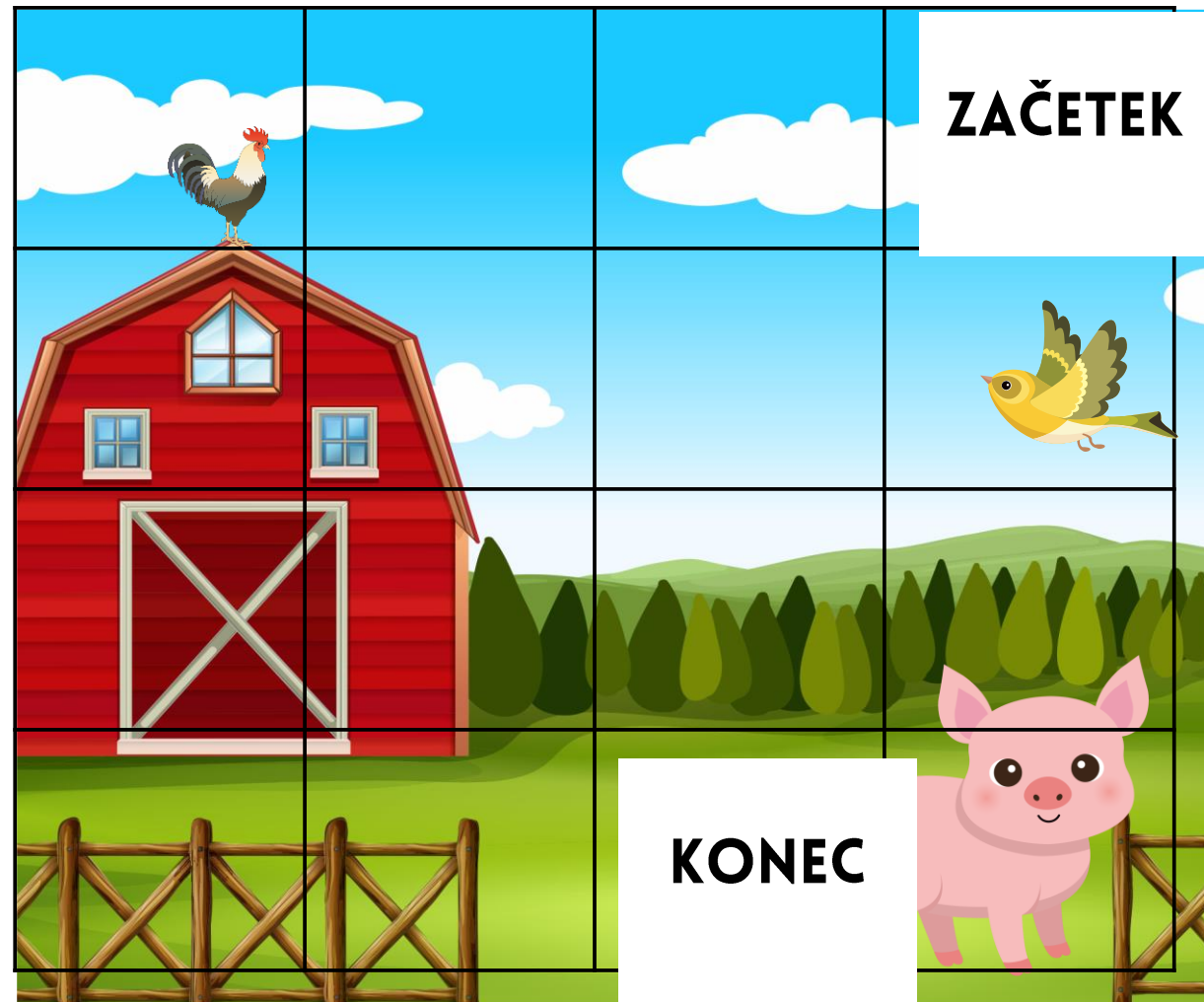

BEE BOT KODIRANJE

Napiši algoritem od ZAČETKA do KONCA.

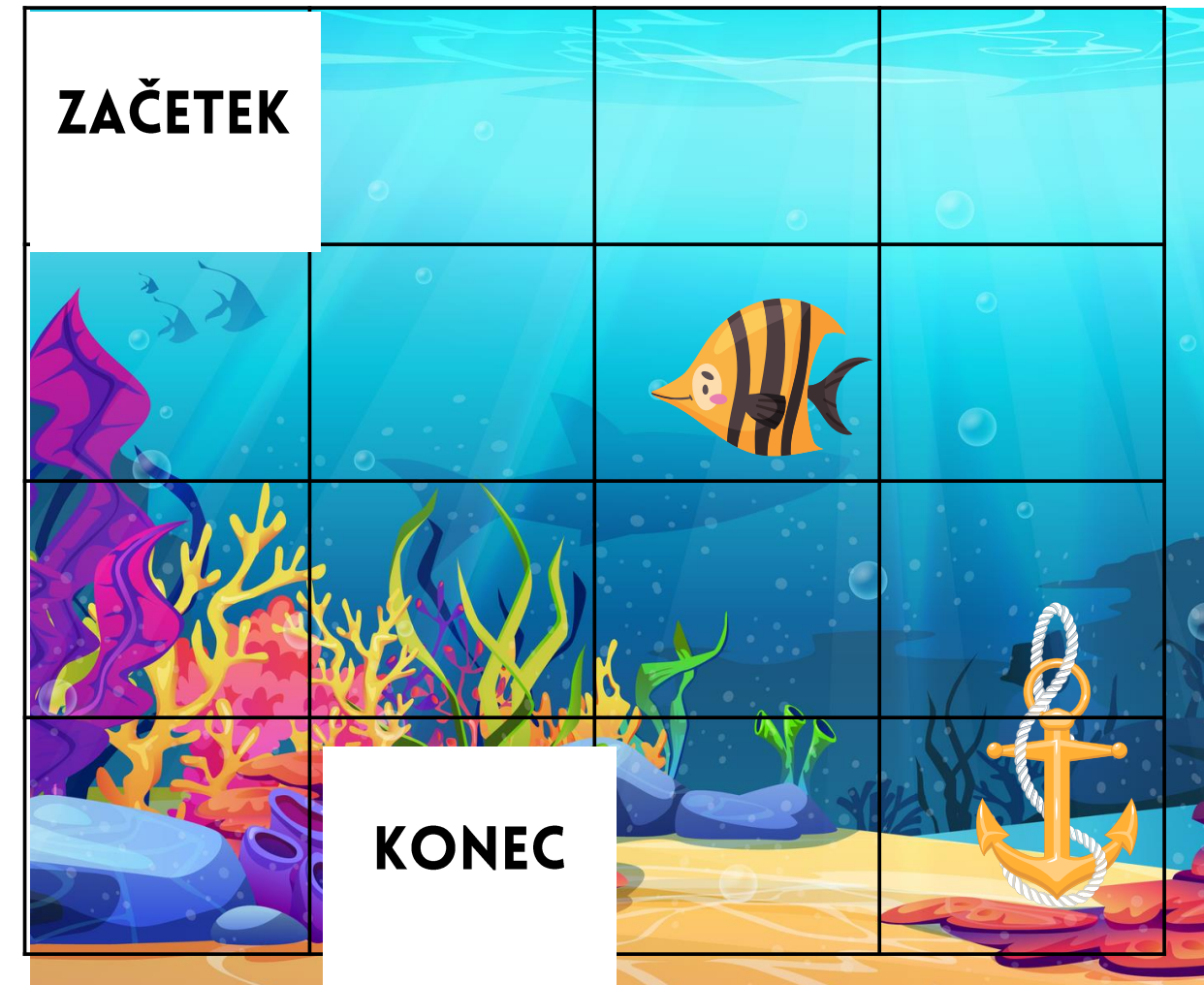

--	--	--	--

BEE BOT KODIRANJE

Napiši algoritem od ZAČETKA do KONCA.



BEE BOT KODIRANJE

Napiši algoritem od ZAČETKA do KONCA.

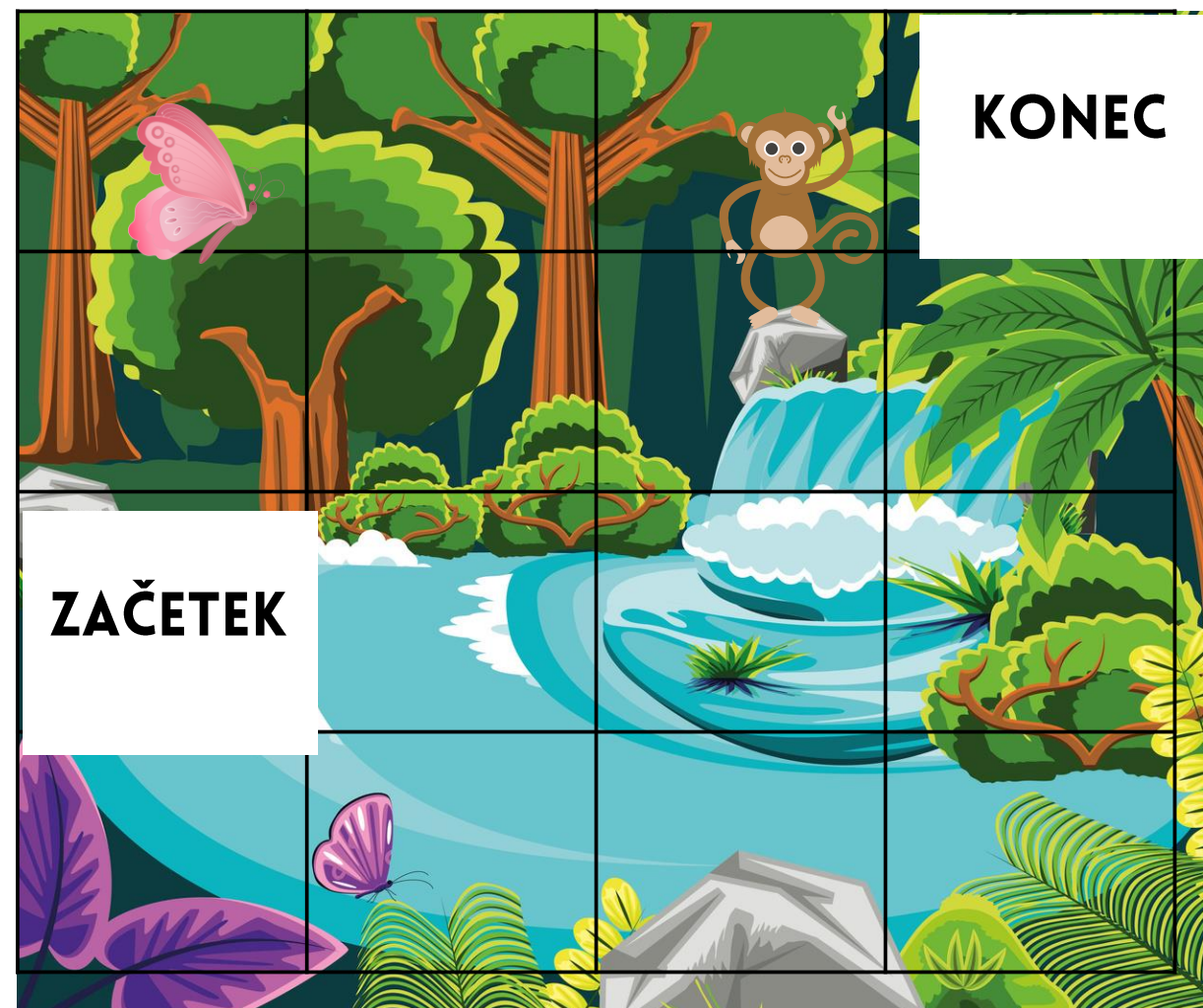

PRIMERI DOBRE PRAKSE

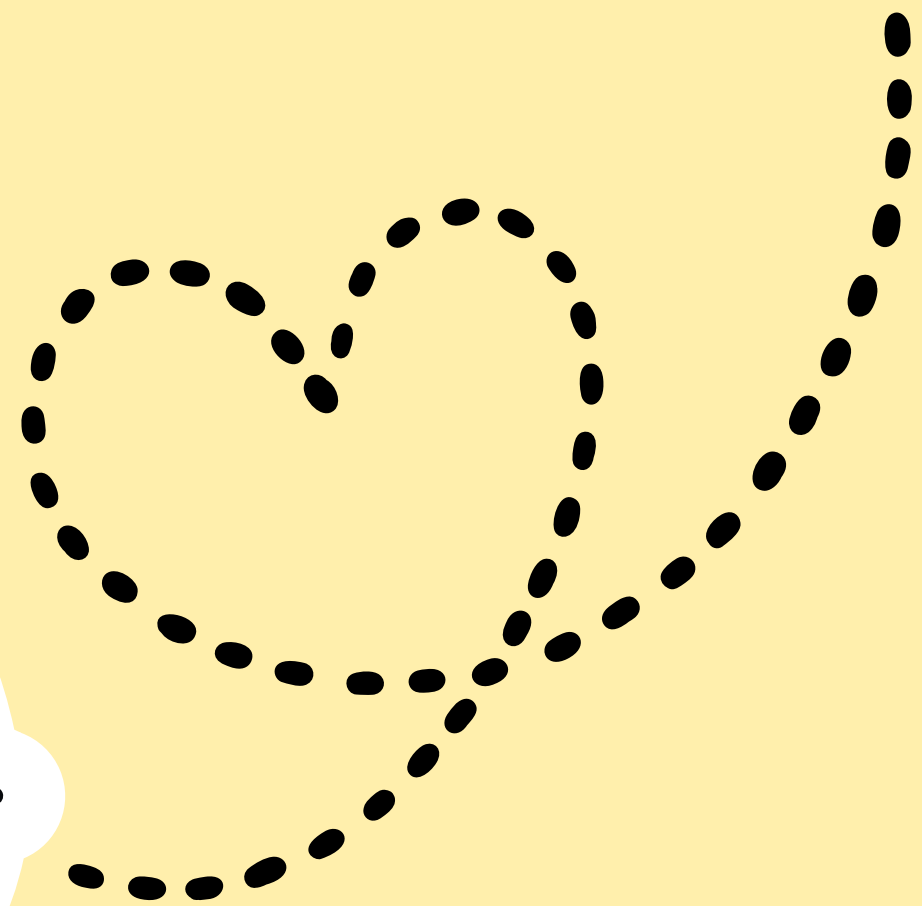
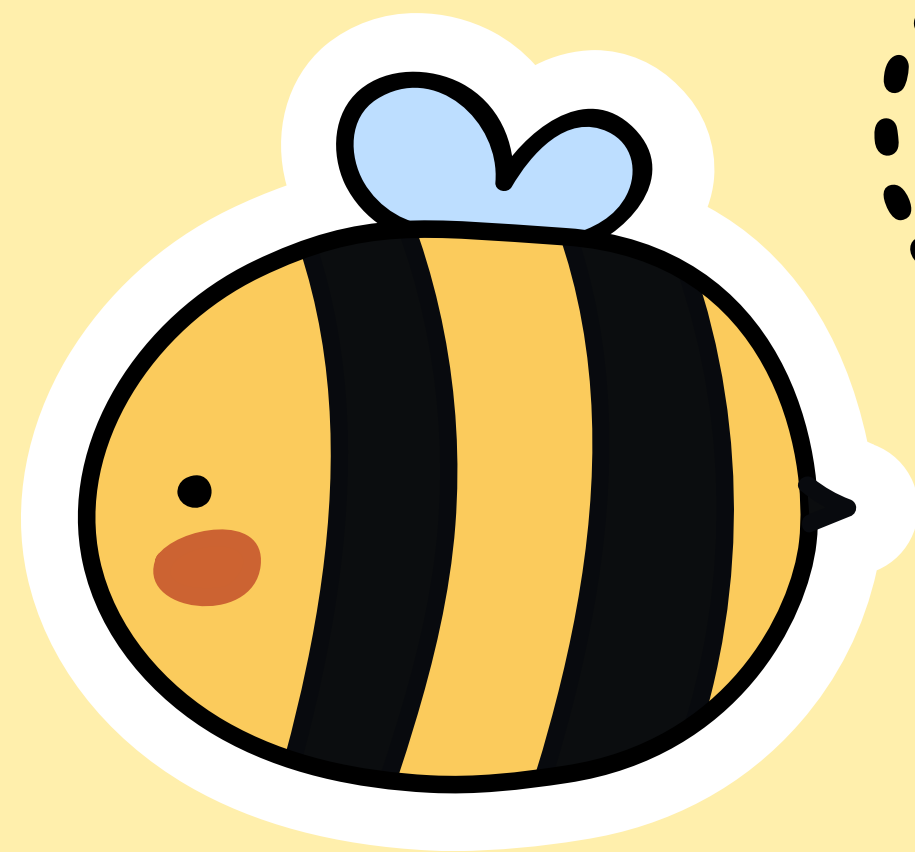





















NALOGA 1

- Premakni Bee-Bota 3 kvadrata naprej.
- Premakni Bee-Bota 2 kvadrata naprej, zavij desno, 1 kvadrat naprej.
- Premakni Bee-Bota 1 kvadrat naprej, zavij levo, 2 kvadrata naprej.



NALOGA 2

Z zapisanimi ukazi pelji Bee Bota po poti. Cilj je označen s samolepilnim listkom.

 DESNO	 DESNO	 NAZAJ	 NAPREJ	 NAPREJ	 POJDI
 POČISTI	 NAPREJ	 DESNO	 DESNO	 POJDI	
 POČISTI	 NAPREJ	 NAPREJ	 povz	 LEVO	 POJDI



NALOGA 3

Postavi Bee Bota na start in ga pripelji do cilja (slika).

Pot si najprej načrtaj na papirju s puščicami.

Nato programiraj Bee Bota in preveri, če pride do cilja.

V kolikor ti ne uspe, popravi napake.

NALOGA 4

IGRA: BEE BOT NA DOGODIVŠČINI

- Bee Bot se nekega dne odpravi na dogodivščino. Pot začne **doma**. Nato gre skozi **park**. Ustavi se na **mostu**. Končno prispe do cilja – **šole**.

Sprogramirajte Bee Bota in ga preizkusite. V kolikor ne pride do cilja - šole, poskusite ponovno.

- Bee Bot se vrača iz šole. Gre skozi gozd in čez pol ure je doma.

Sprogramirajte Bee Bota in ga preizkusite. V kolikor ne pride do cilja - šole, poskusite ponovno.



DIPLOMO

ZA SUPER PROGRAMERJA
BEE BOTA

PREJME

IME IN PRIIMEK

Podpis:

Datum: 14.5.2025

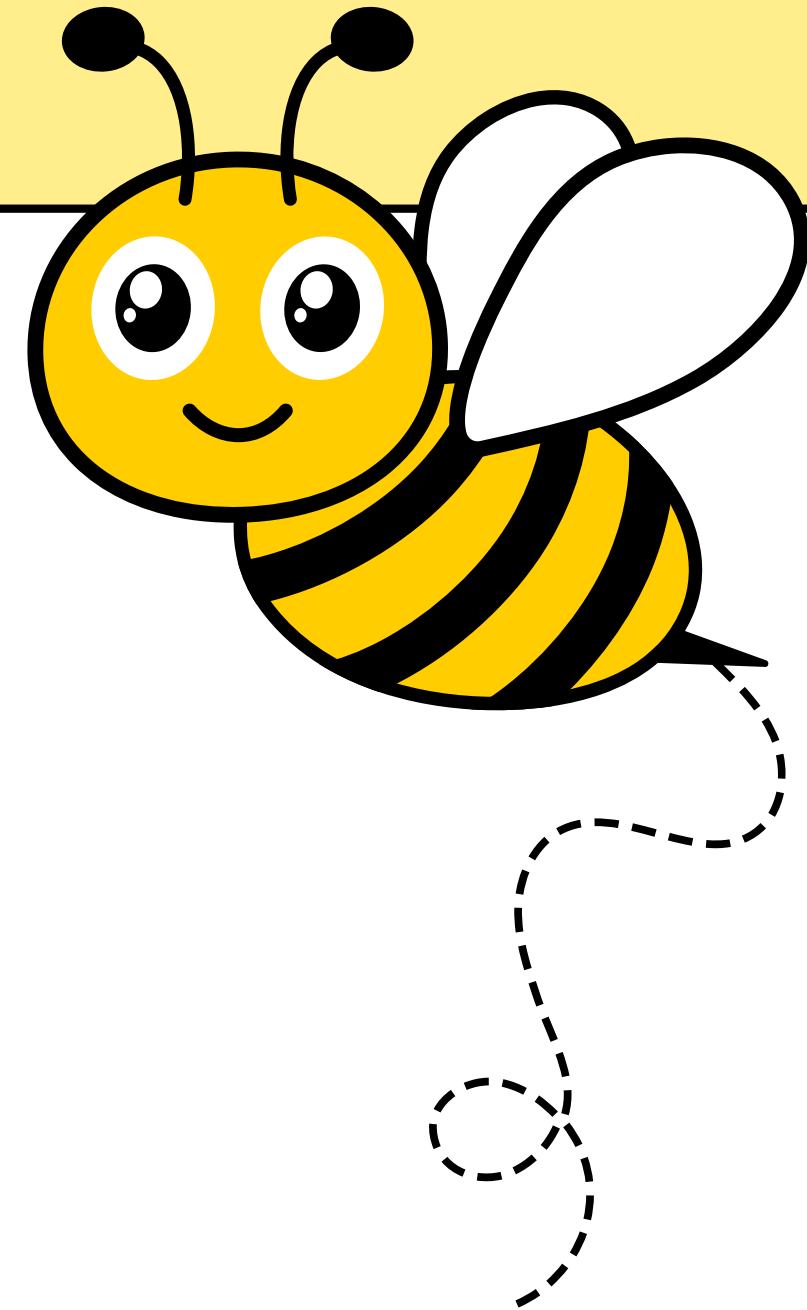



ROBOT mTINY

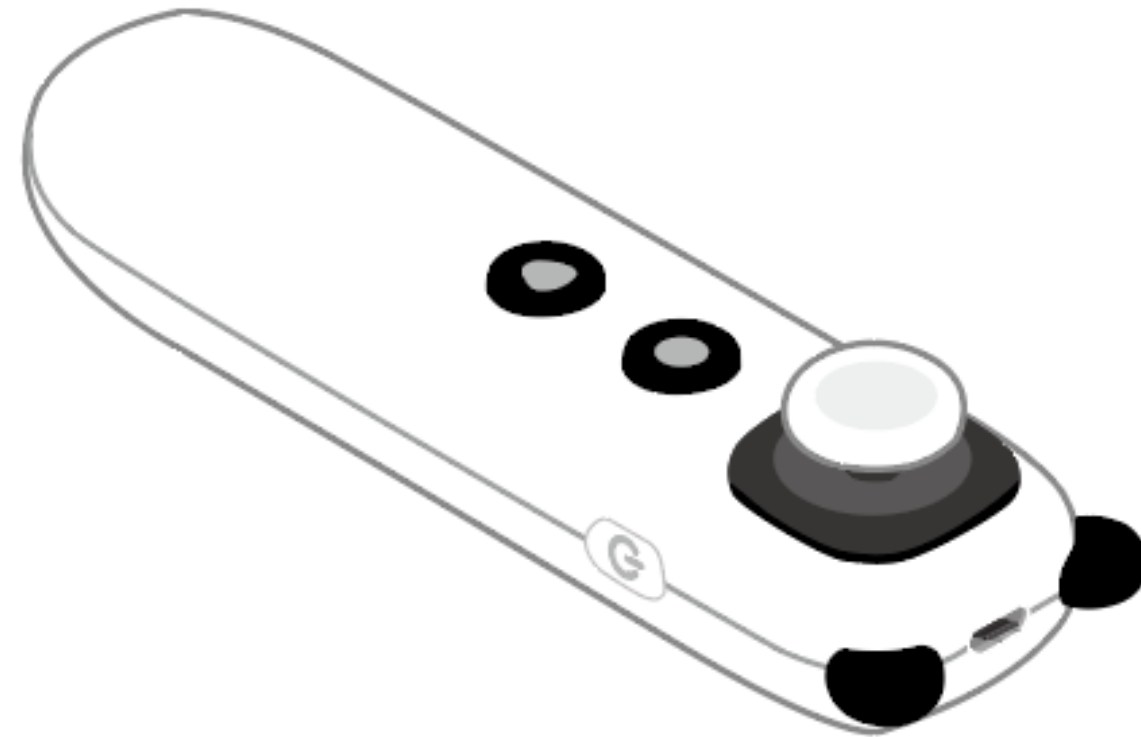
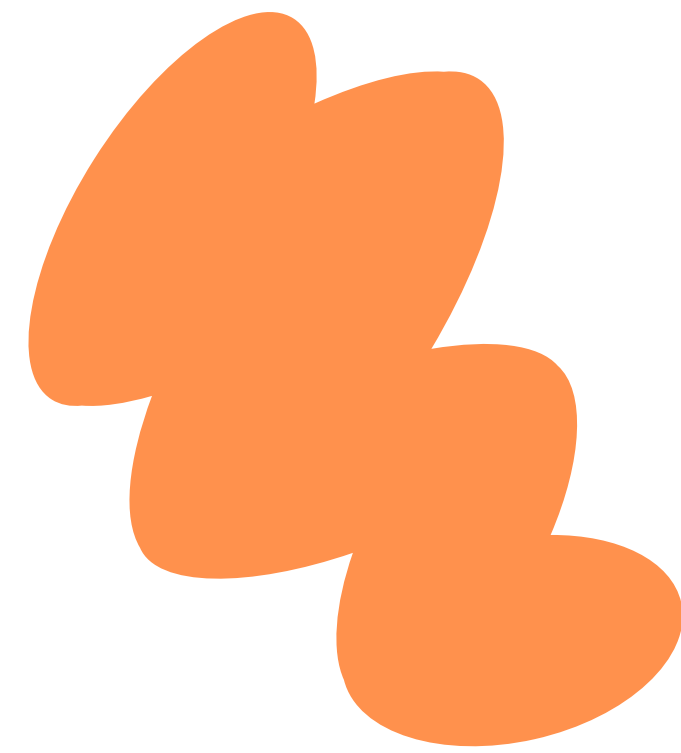

KAJ JE mTINY?

- izobraževalni robotek
- namenjen predvsem mlajšim učencem (1. in 2. razred).
- delovanje po principu programiranja brez zaslona -
upravljanje s . kodirnim peresom in karticami s simboli.
- učenje logičnega razmišljanja, osnov programiranja,
orientacije v prostoru ter sodelovanja.

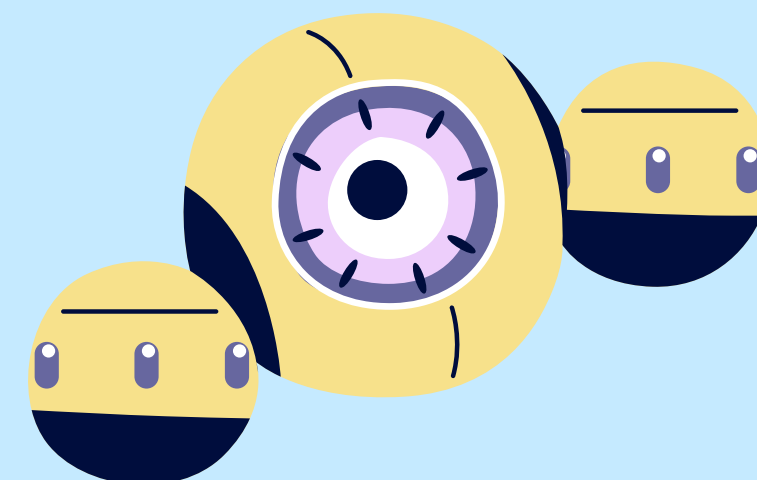

KAKO DELUJE?

- upravljanje s kodirnim peresom, ki bere kartice s simboli.
- kartice pomenijo ukaze:
naprej, nazaj, levo, desno, zvok, ples, čustva...
- robotek se odziva s premikanjem, zvoki, mimiko in izražanjem čustev

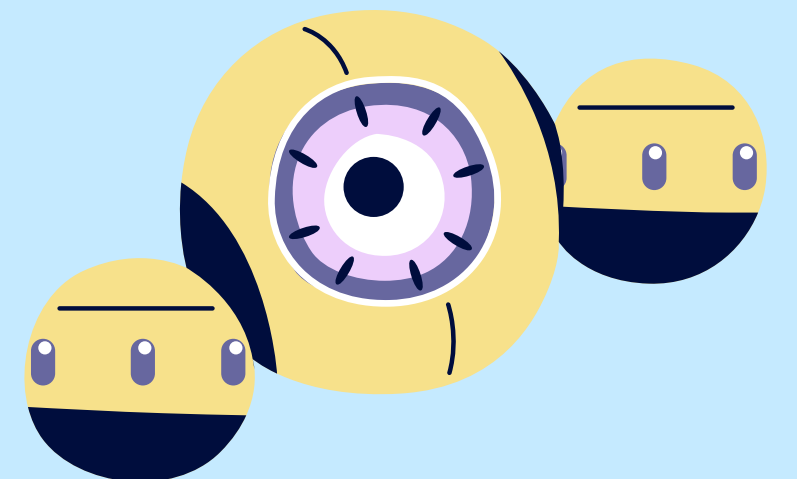











KAJ PRIDOBIMO UČENCI?

- ✓ Osnovne koncepte računalniškega mišljenja (zaporedje, ponavljanje, vzročno-posledične povezave).
- ✓ Spretnosti reševanja problemov.
- ✓ Učenje skozi igro in zgodbo.
- ✓ Razvijanje komunikacije in sodelovanja v skupini.

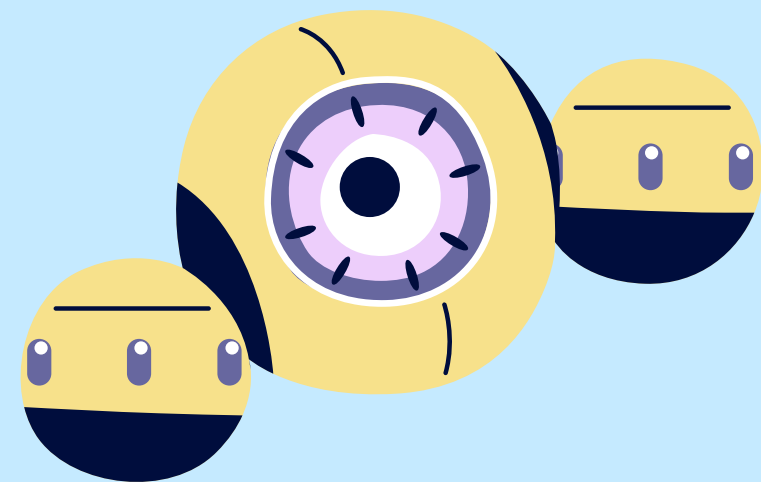

DELAVNICA 3

ROBOT MTINY

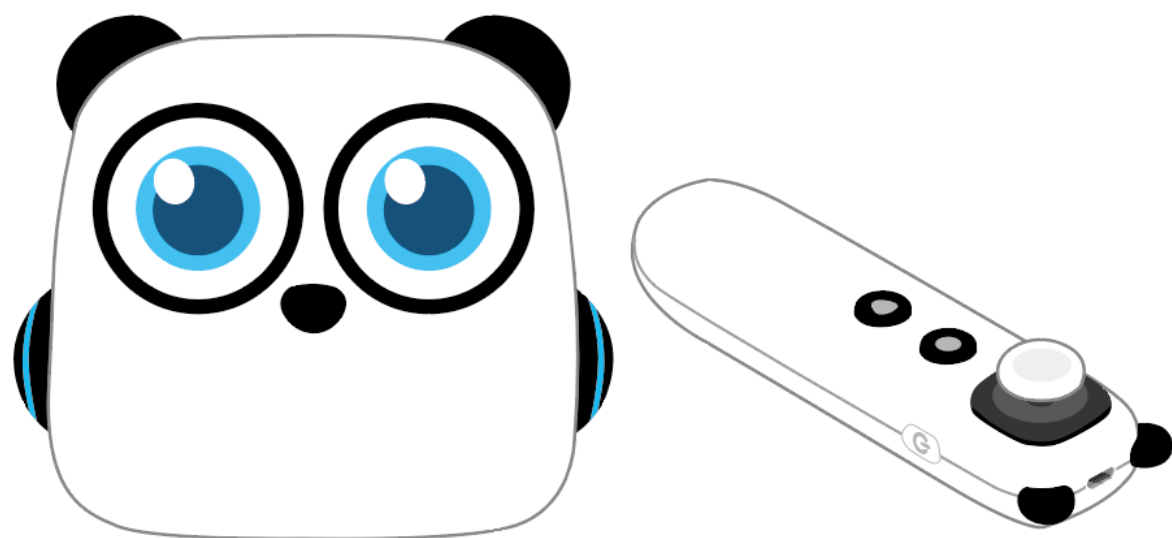

Datum: 28. maj 2025

ROBOT

SIMETRIJA

DOPOLNI SLIKO ROBOTKA.

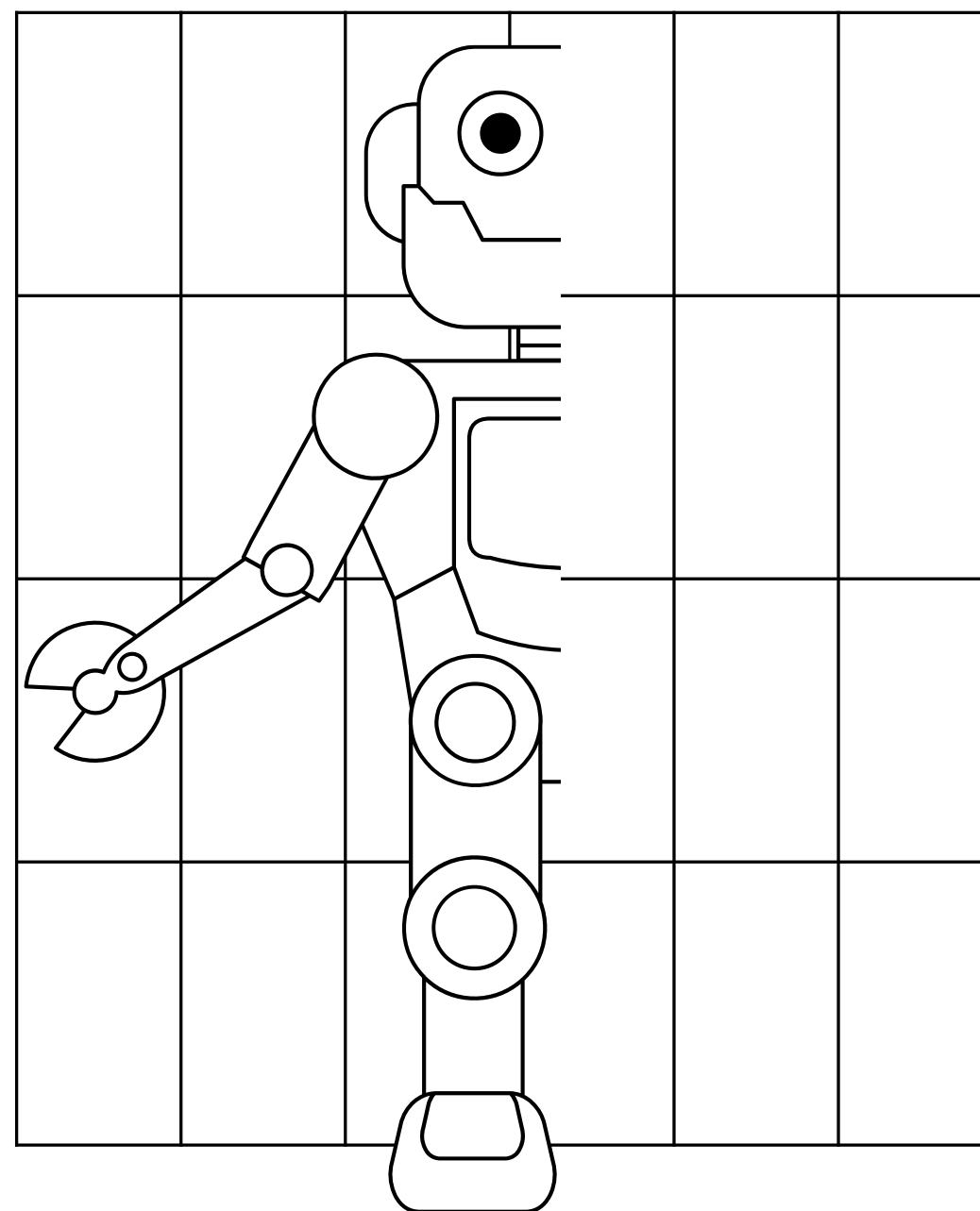

KAKO MI JE BILA DELAVNICA Z ROBOTKOM VŠEČ?

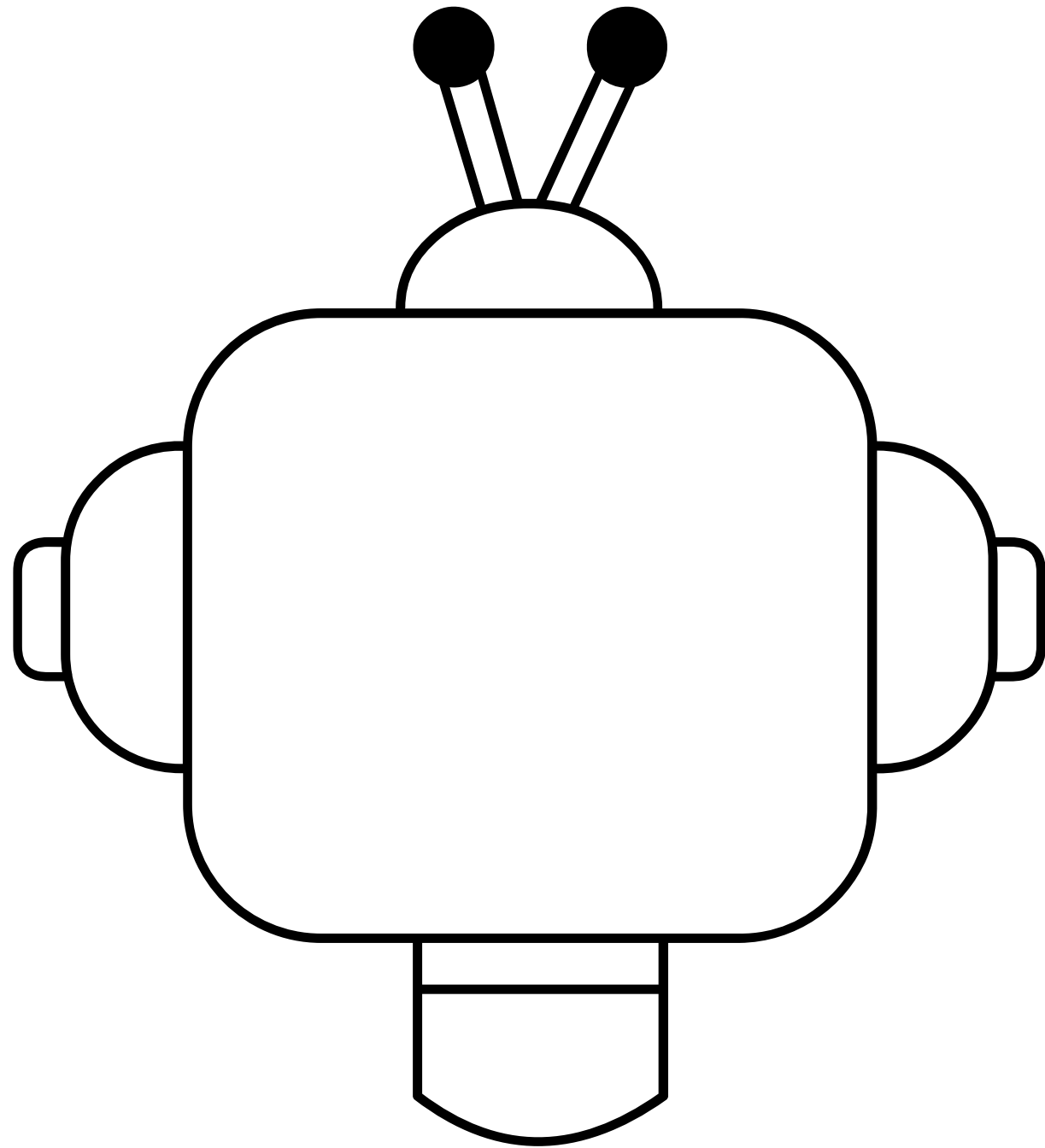

LABIRINTI

POMAGAJ ROBOTU DOKONČATI

SPODNJE LABIRINTE!

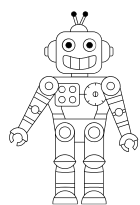

START

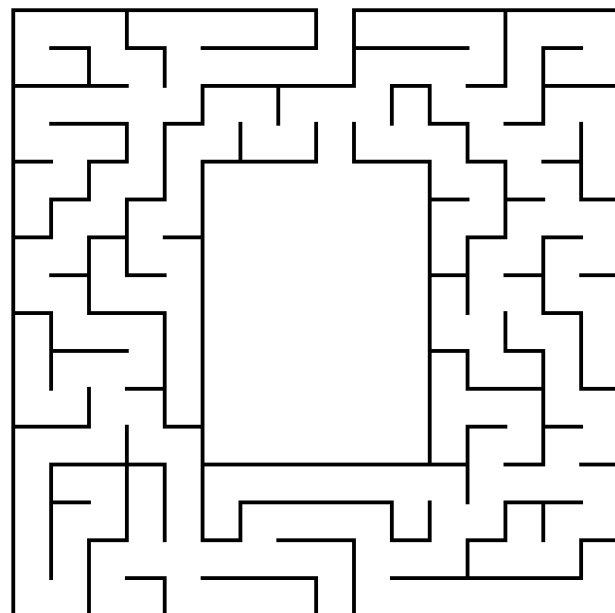

START

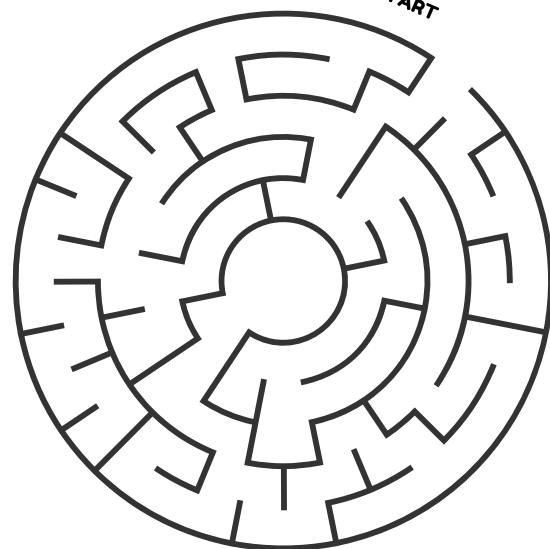

CILJ

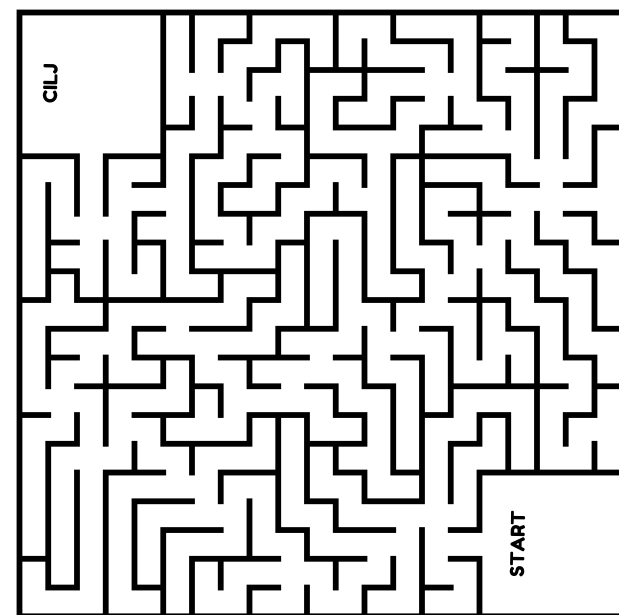

START

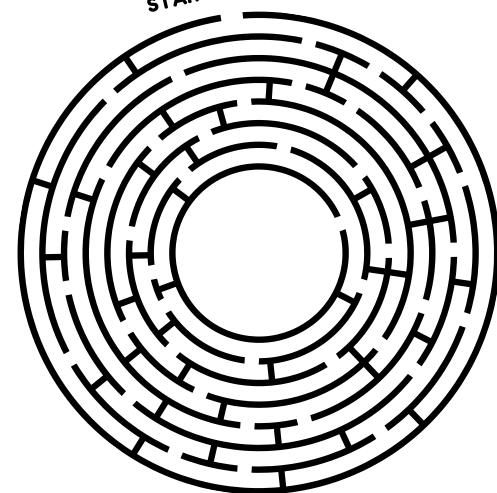

IZDELAJ ROBOTA

POBARVAJ, IZREŽI IN ZALEPI ROBOTKA.

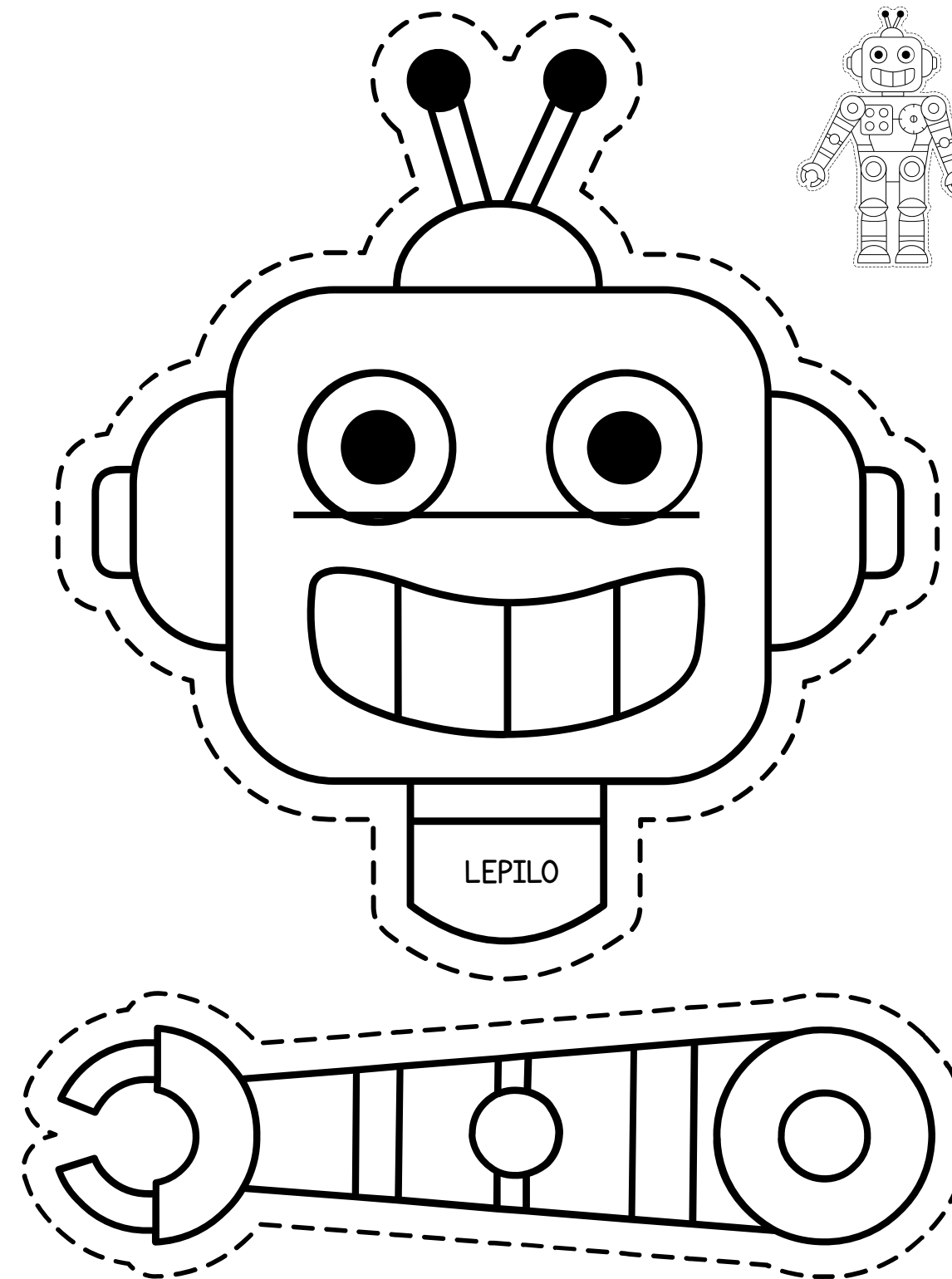
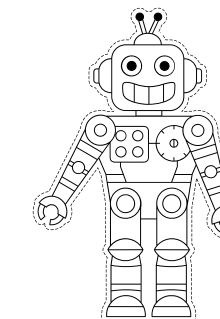

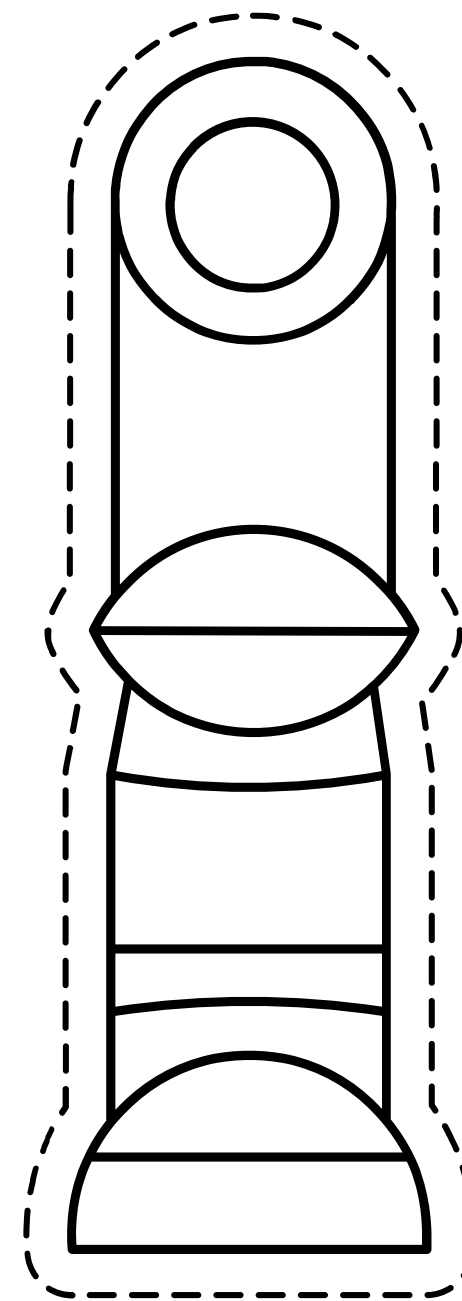
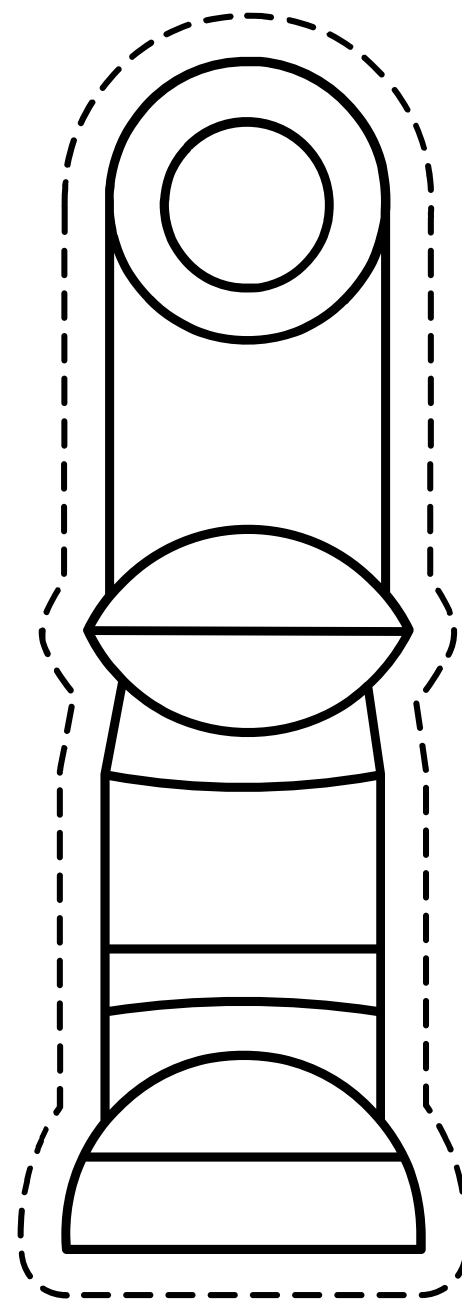
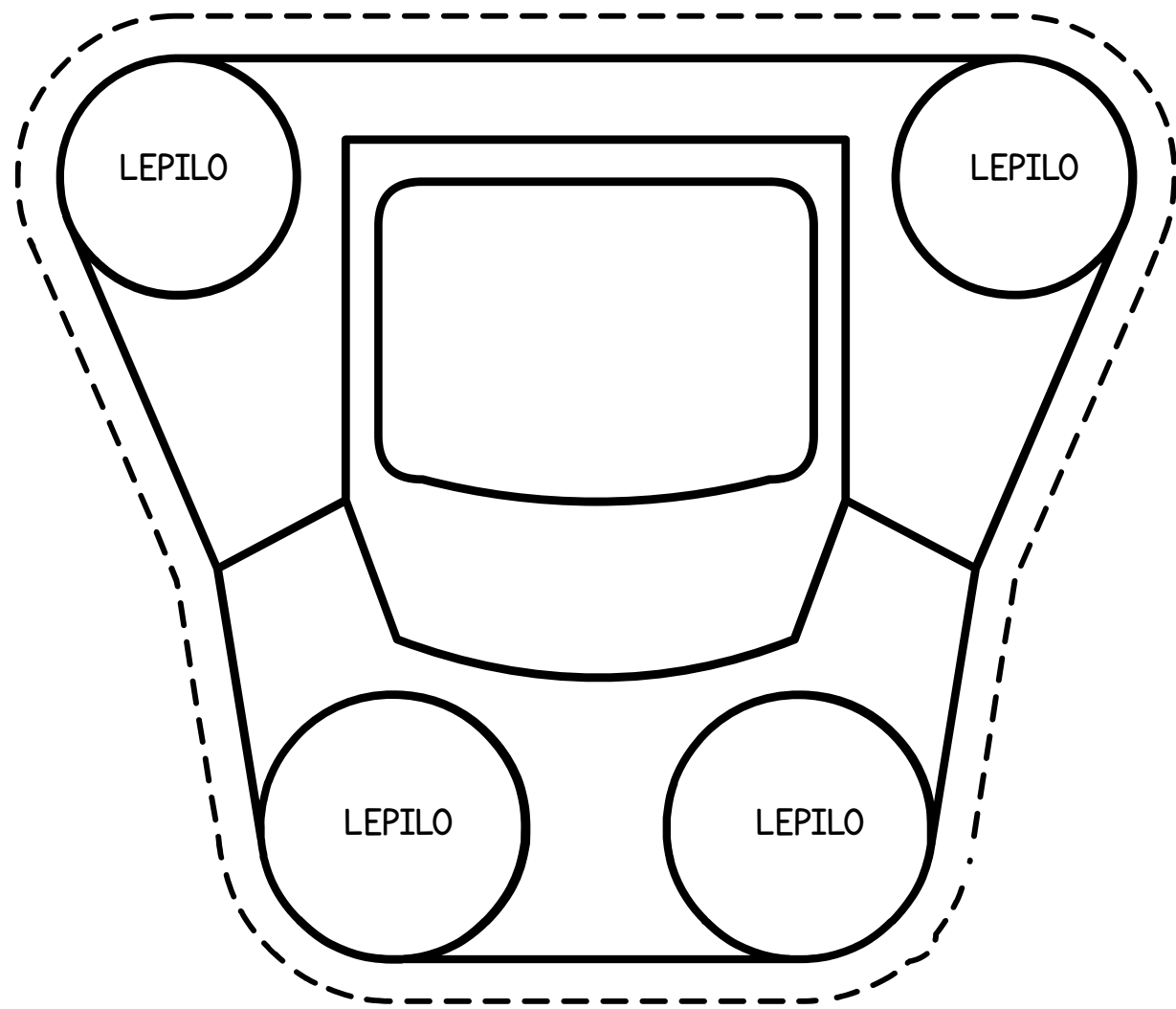
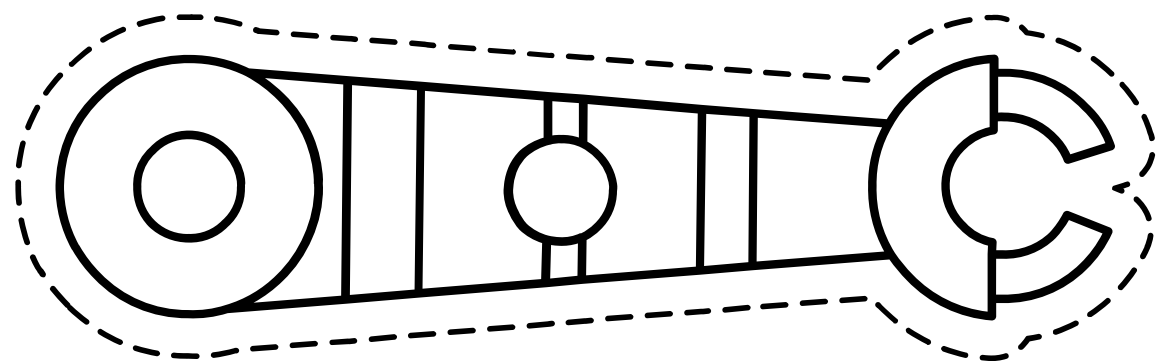

Č E S T I T K E

PROGRAMER

robota mTiny



M A J
2 0 2 5



T PET

OBVESTILA
UČITELEM OPB

0 1 2 3 4 5 6 7 8 9 10 11 12 13 14 15 16 17 18

KARLI

MILIA

PINO

OBVESTILA
UČITELEM OPB

OBVESTILA
UČITELEM OPB

OBVESTILA
UČITELEM OPB

PRIMERI DOBRE PRAKSE



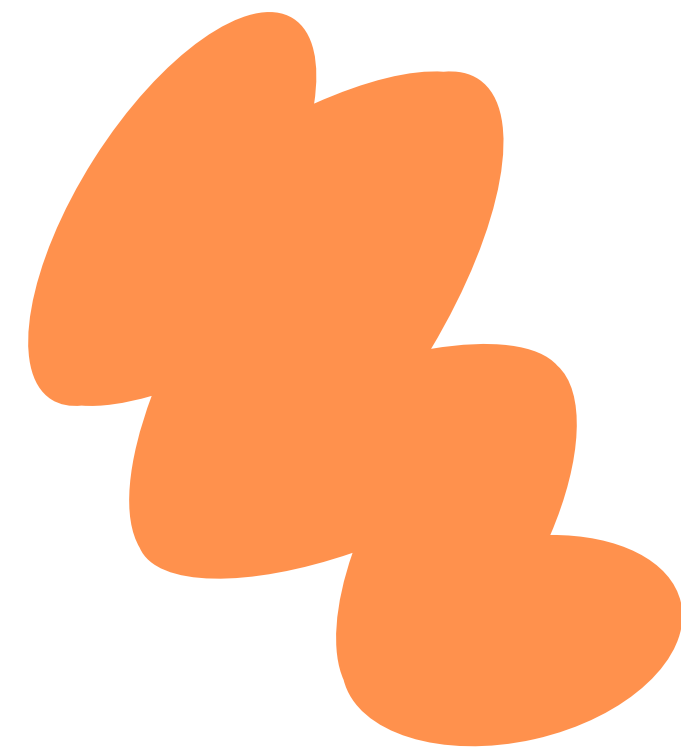

NAJDI PRAVI REZULTAT

(matematika)



RAČUN	REZULTAT	UKAZI
43 + 12 =	55	→ ↓ → → ↓











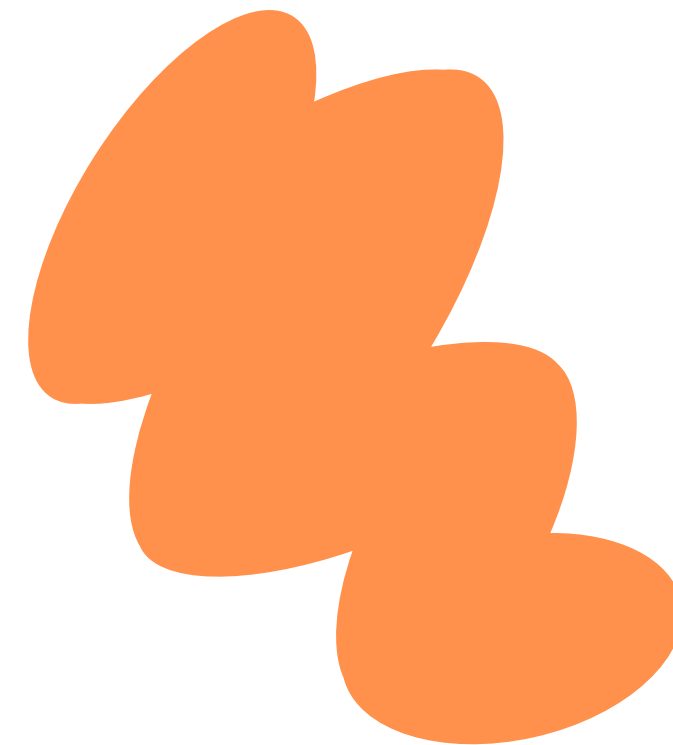

RAZMIGAJ SE

(šport)







VISOKO DVIGU KOLEGA
(TEK NA MESTU).

POSTAVI SE OB STENO IN
NAREDI NEVIDNI STOL.





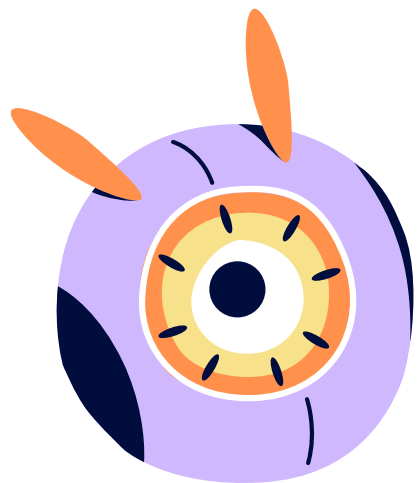

SESTAVI SVOJO ZGODBO

(slovenščina)







OBISK PODJETJA

strokasi







strokasi





Začeli smo... Čaka nas še veliko spoznanj v svetu tehnologije.

Prihodnje šolsko leto bomo gradili naprej, reševali nove izzive in skupaj odkrivali, kako zabavno in poučno je učenje z robotiko.

